

Features

- Epitaxial planar die construction
- Ideal for low power amplification and switching
- High current gain

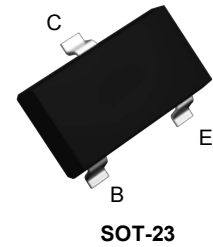

Absolute Maximum Ratings ($T_A=25^\circ\text{C}$ unless otherwise noted)

Parameter	Symbol	Value	Unit
Collector Base Voltage	V_{CB0}	40	V
Collector Emitter Voltage	V_{CE0}	40	V
Emitter Base Voltage	V_{EB0}	5	V
Collector Current	I_C	1	A
Peak Pulse Current	I_{CM}	2	A
Total Power Dissipation ¹	P_{tot}	350	mW
Max. Thermal Resistance from Junction to Ambient ¹	$R_{\theta JA}$	357	$^\circ\text{C}/\text{W}$
Junction Temperature	T_J	150	$^\circ\text{C}$
Storage Temperature Range	T_{STG}	-55 to +150	$^\circ\text{C}$

Note:

1. Device mounted on FR-4 substrate PC board, with minimum recommended pad layout.

Electrical Characteristics ($T_A=25^\circ\text{C}$ unless otherwise noted)

Parameter	Symbol	Conditions	Min.	Max.	Unit
Collector Base Breakdown Voltage	$V_{(BR)CB0}$	$I_C=10\mu\text{A}$	40	-	V
Collector Emitter Breakdown Voltage	$V_{(BR)CE0}$	$I_C=1\text{mA}$	40	-	V
Emitter Base Breakdown Voltage	$V_{(BR)EB0}$	$I_E=10\mu\text{A}$	5	-	V
Collector Base Cutoff Current	I_{CB0}	$V_{CB}=30\text{V}$	-	100	nA
Collector Emitter Cutoff Current	I_{CES}	$V_{CE}=30\text{V}$	-	100	nA
Emitter Base Cutoff Current	I_{EBO}	$V_{EB}=4\text{V}$	-	100	nA
DC Current Gain	h_{FE}	$V_{CE}=5\text{V}, I_C=1\text{mA}$	300	-	-
		$V_{CE}=5\text{V}, I_C=500\text{mA}$	300	900	-
		$V_{CE}=5\text{V}, I_C=1\text{A}$	200	-	-
Collector Emitter Saturation Voltage	$V_{CE(sat)}$	$I_C=500\text{mA}, I_B=50\text{mA}$	-	0.3	V
		$I_C=1\text{A}, I_B=100\text{mA}$	-	0.5	
Base Emitter Saturation Voltage	$V_{BE(sat)}$	$I_C=1\text{A}, I_B=100\text{mA}$	-	1.2	V
Base Emitter Voltage	V_{BE}	$I_C=1\text{A}, V_{CE}=5\text{V}$	-	1.1	V
Collector Output Capacitance	C_{ob}	$V_{CB}=10\text{V}, f=1\text{MHz}$	-	10	pF
Transition Frequency	f_T	$V_{CE}=10\text{V}, I_C=50\text{mA}, f=100\text{MHz}$	150	-	MHz

Electrical Characteristic Curves

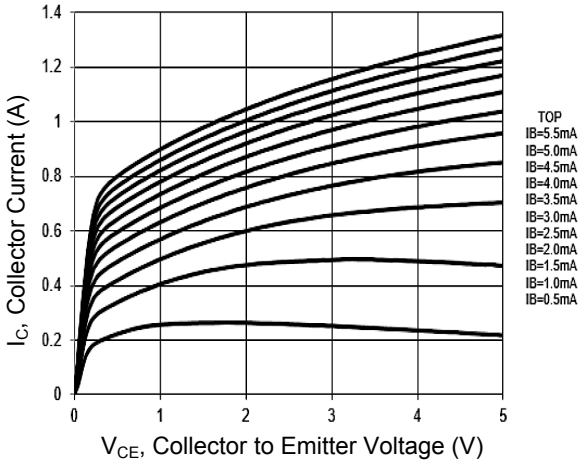

Figure 1. Output Characteristics Curve

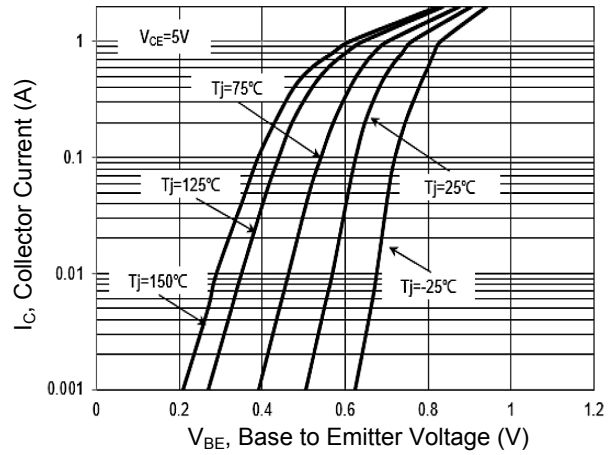

Figure 2. Collector Current vs. Base to Emitter Voltage

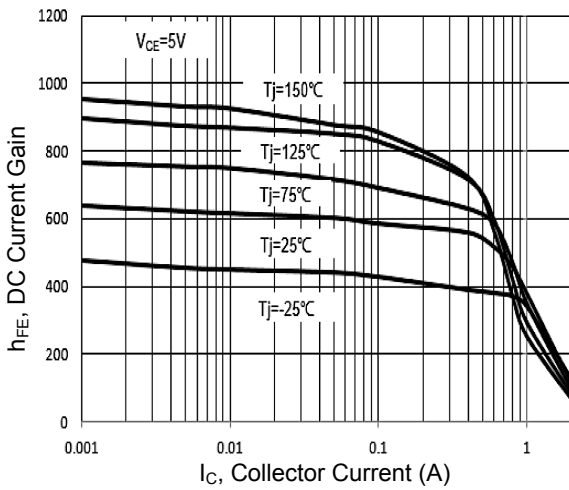

Figure 3. DC Current Gain vs. Collector Current

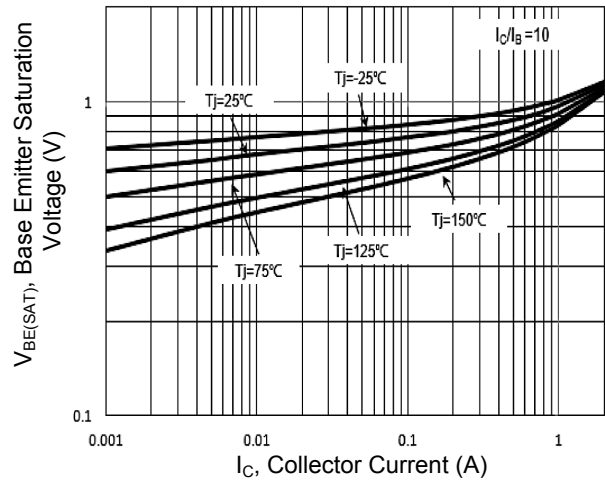

Figure 4. Base Emitter Saturation Voltage vs. Collector Current

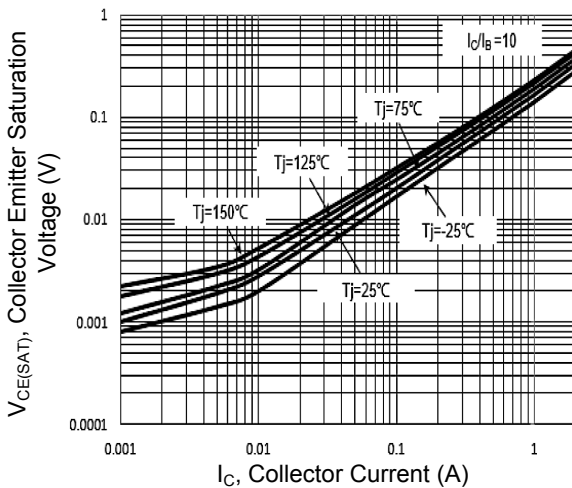

Figure 5. Collector Emitter Saturation Voltage vs. Collector Current

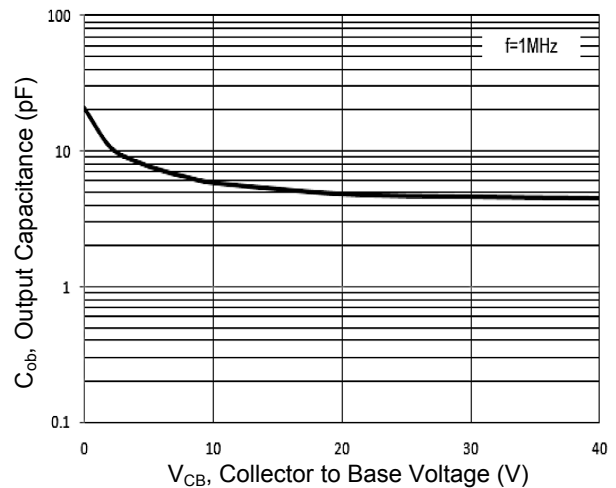

Figure 6. Output Capacitance

Electrical Characteristic Curves

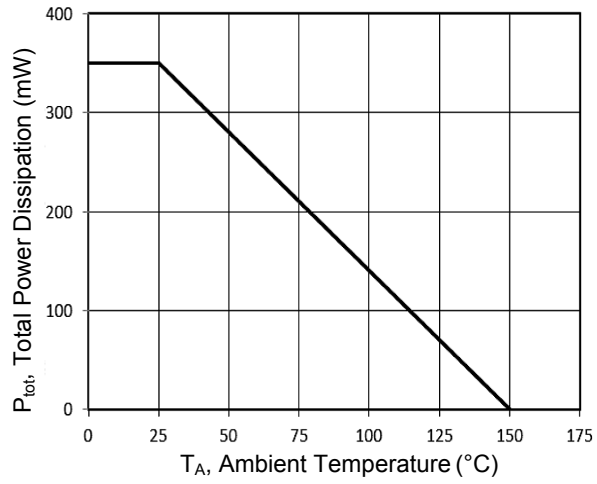
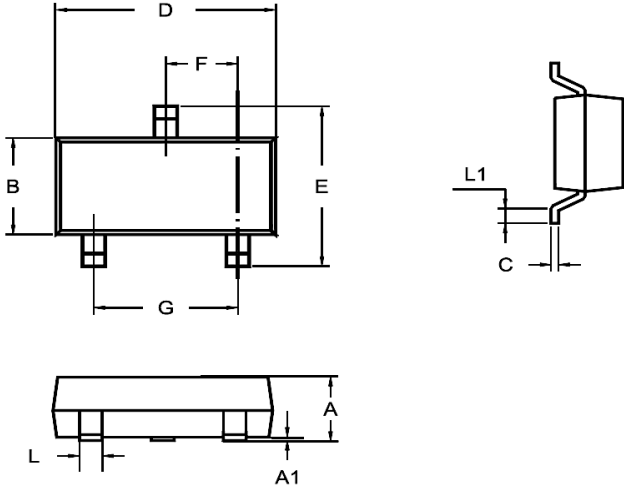

Figure 7. Power Derating Curve

Package Outline Dimensions (SOT-23)



Symbol	Dimensions In Millimeters		Dimensions In Inches	
	Min.	Max.	Min.	Max.
A	0.890	1.200	0.035	0.047
A1	0.013	0.100	0.001	0.004
B	1.200	1.400	0.047	0.055
C	0.080	0.190	0.003	0.007
D	2.800	3.040	0.110	0.120
E	2.200	2.600	0.087	0.102
F	0.890	1.020	0.035	0.040
G	1.780	2.040	0.070	0.080
L	0.370	0.510	0.015	0.020
L1	0.200	-	0.008	-

Recommended Pad Layout

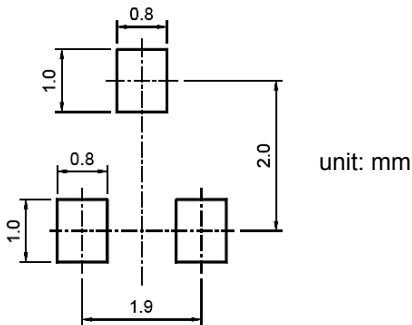

Ordering Information

Device	Package	Marking	Packaging	SPQ
GSMMBT491A	SOT-23	ZM	Tape & Reel	3,000 Pcs / Reel