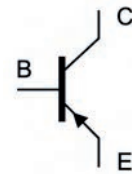
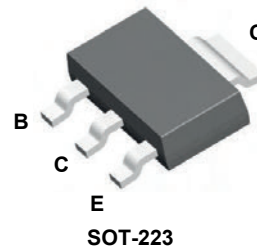


## Features

- For AF driver and output stages
- High collector current
- Low collector-emitter saturation voltage
- Complementary types: GSBCP54/GSBCP55/GSBCP56 (NPN)



Schematic Diagram

## Absolute Maximum Ratings ( $T_A=25^\circ\text{C}$ unless otherwise noted)

Parameter	Symbol	GSBCP51	GSBCP52	GSBCP53	Unit
Collector-Base Voltage	$V_{CBO}$	-45	-60	-100	V
Collector-Emitter Voltage	$V_{CEO}$	-45	-60	-80	V
Emitter-Base Voltage	$V_{EBO}$		-5		V
Collector Current-Continuous	$I_C$		-1		A
Peak Pulse Collector Current	$I_{CM}$		-2		A
Base Current-Continuous	$I_B$		-100		mA
Peak Pulse Base Current	$I_{BM}$		-200		mA
Collector Power Dissipation	$P_C$		1.5		W
Thermal Resistance Junction to Ambient	$R_{\theta JA}$		94		$^\circ\text{C/W}$
Operation Junction and Storage Temperature Range	$T_J, T_{stg}$		-55 to +150		$^\circ\text{C}$

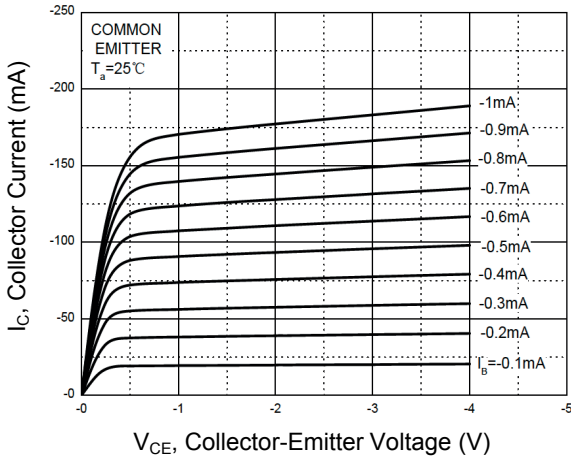
## Electrical Characteristics ( $T_A=25^\circ\text{C}$ unless otherwise noted)

Parameter	Symbol	Test Conditions	Min	Max	Unit
Collector-Base Breakdown Voltage	GSBCP51	$I_C=-0.1\text{mA}, I_E=0$	-45	-	V
	GSBCP52		-60	-	
	GSBCP53		-100	-	
Collector-Emitter Breakdown Voltage	GSBCP51	$I_C=-10\text{mA}, I_B=0$	-45	-	V
	GSBCP52		-60	-	
	GSBCP53		-80	-	
Base-Emitter Breakdown Voltage	$V_{(BR)EBO}$	$I_E=-10\mu\text{A}, I_C=0$	-5	-	V
Collector Cut-Off Current	$I_{CBO}$	$V_{CB}=-30\text{V}, I_E=0$	-	-100	nA
DC Current Gain	$h_{FE(1)}$	$V_{CE}=-2\text{V}, I_C=-5\text{mA}$	25	-	-
	$h_{FE(2)}$	$V_{CE}=-2\text{V}, I_C=-150\text{mA}$	63	250	-
	$h_{FE(3)}$	$V_{CE}=-2\text{V}, I_C=-500\text{mA}$	25	-	-
Collector-Emitter Saturation Voltage	$V_{CE(sat)}$	$I_C=-500\text{mA}, I_B=-50\text{mA}$	-	-0.5	V
Base-Emitter Voltage	$V_{BE}$	$V_{CE}=-2\text{V}, I_C=-500\text{mA}$	-	-1	V
Transition Frequency	$f_T$	$V_{CE}=-10\text{V}, I_C=-50\text{mA}, f=100\text{MHz}$	100	-	MHz

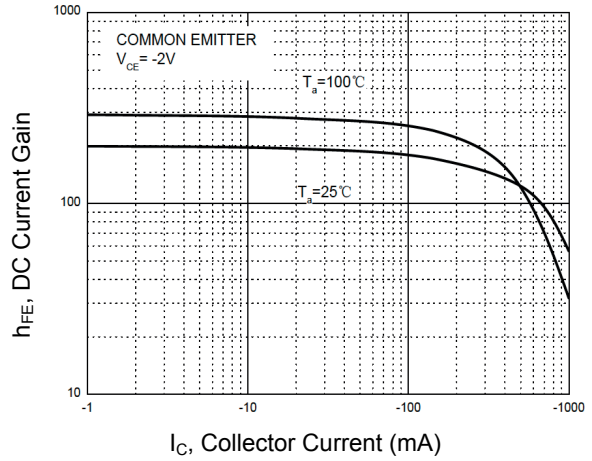
## Classification of $h_{FE(2)}$

Rank	GSBCP51-10, GSBCP52-10, GSBCP53-10	GSBCP51-16, GSBCP52-16, GSBCP53-16
Range	63-160	100-250

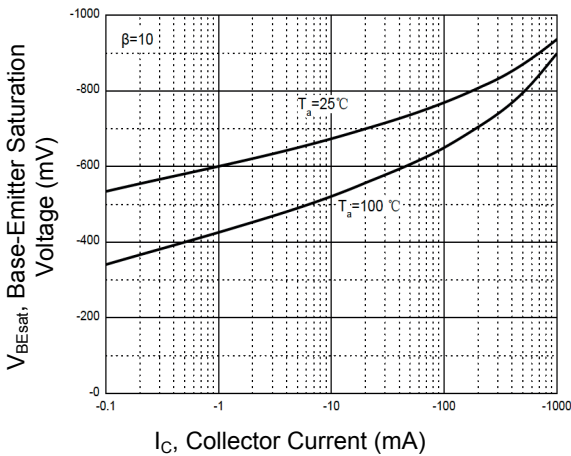
**Typical Electrical Characteristic Curves**



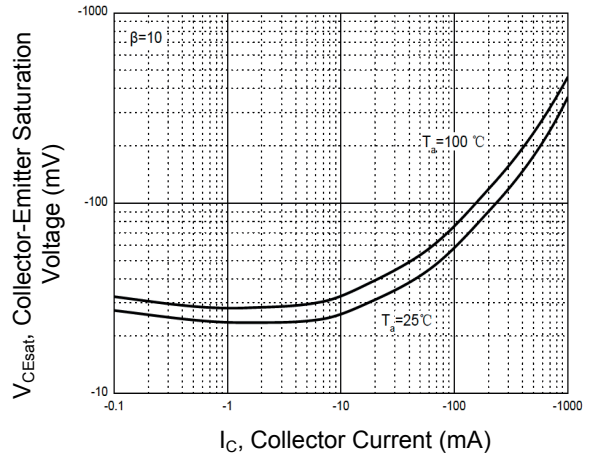
**Figure 1. Static Characteristics**



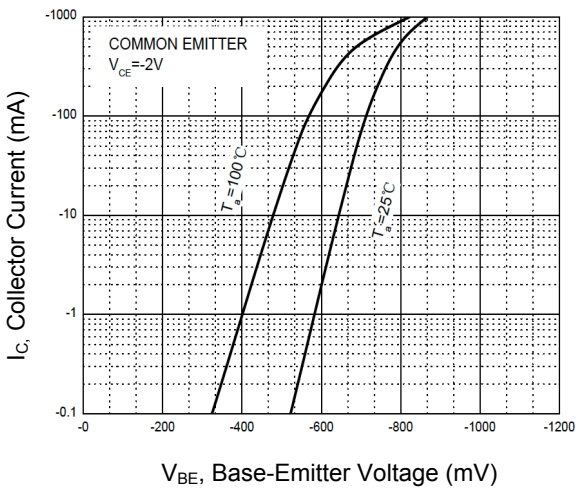
**Figure 2. DC Current Gain vs. Collector Current**



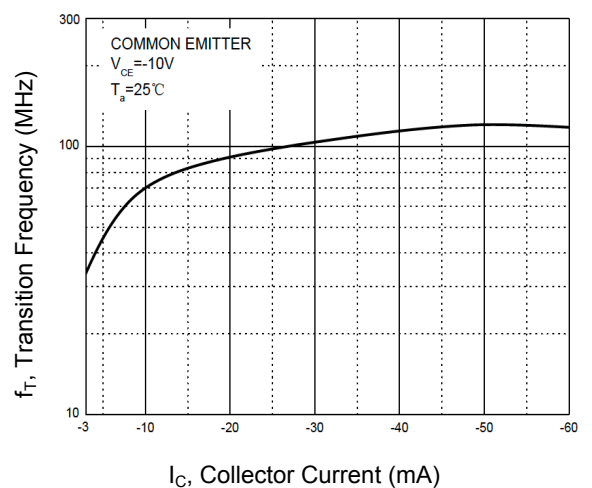
**Figure 3. Base-Emitter Saturation Voltage vs. Collector Current**



**Figure 4. Collector-Emitter Saturation Voltage vs. Collector Current**

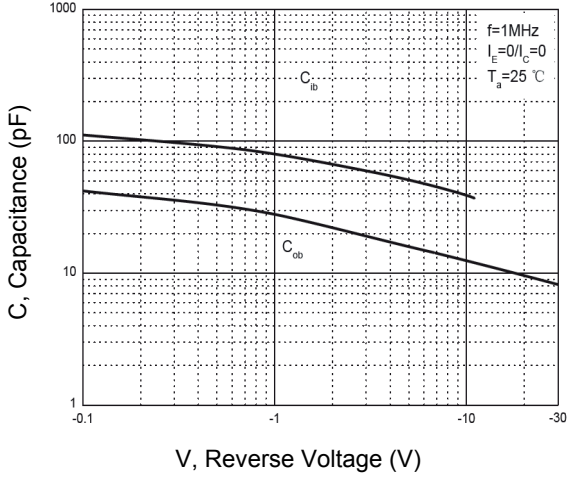


**Figure 5. Collector Current vs. Base-Emitter Voltage**

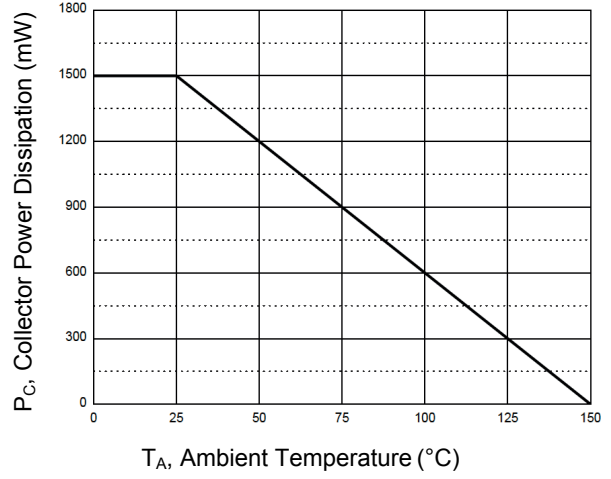


**Figure 6. Transition Frequency vs. Collector Current**

**Typical Electrical Characteristic Curves**

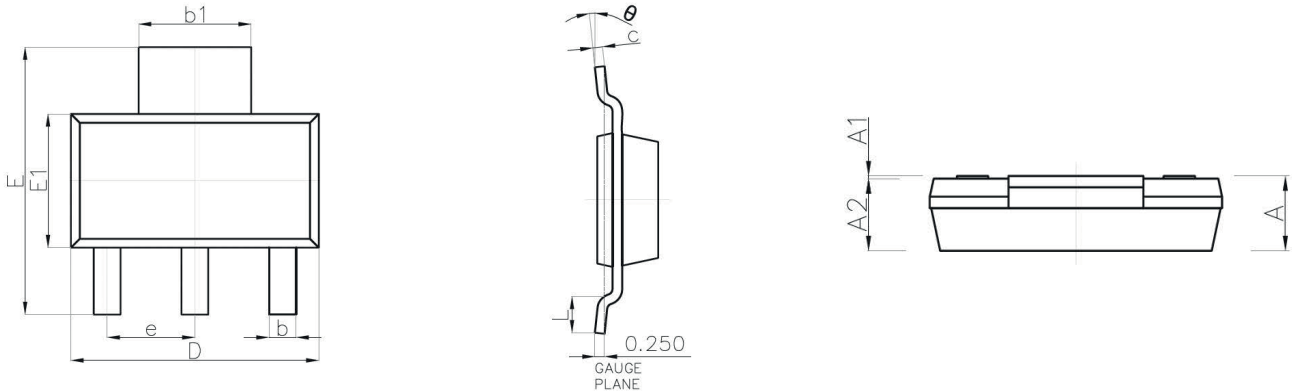


**Figure 7. Capacitance Characteristics**



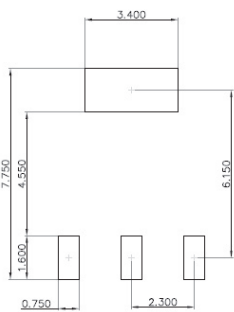
**Figure 8. Power Dissipation vs. Ambient Temperature**

**Package Outline Dimensions (SOT-223)**



Symbol	Dimensions In Millimeters		Dimensions In Inches	
	Min.	Max.	Min.	Max.
A	-	1.800	-	0.071
A1	0.020	0.100	0.001	0.004
A2	1.500	1.700	0.059	0.067
b	0.660	0.840	0.026	0.033
b1	2.900	3.100	0.114	0.122
c	0.230	0.350	0.009	0.014
D	6.300	6.700	0.248	0.264
E	6.700	7.300	0.264	0.287
E1	3.300	3.700	0.130	0.146
e	2.300 (BSC)		0.091 (BSC)	
L	0.750	-	0.030	-
θ	0°	10°	0°	10°

**Recommended Pad Layout**



Note:

1. Controlling dimension: in millimeters.
2. General tolerance:  $\pm 0.05\text{mm}$ .
3. The pad layout is for reference purposes only.

**Order Information**

Device	Package	Marking	Packaging	SPQ
GSBCP51-10	SOT-223	BCP51-10	Tape & Reel	2,500pcs / Reel
GSBCP51-16	SOT-223	BCP51-16	Tape & Reel	2,500pcs / Reel
GSBCP52-10	SOT-223	BCP52-10	Tape & Reel	2,500pcs / Reel
GSBCP52-16	SOT-223	BCP52-16	Tape & Reel	2,500pcs / Reel
GSBCP53-10	SOT-223	BCP53-10	Tape & Reel	2,500pcs / Reel
GSBCP53-16	SOT-223	BCP53-16	Tape & Reel	2,500pcs / Reel

For more information, please contact us at: [inquiry@goodarksemi.com](mailto:inquiry@goodarksemi.com)