

Features

- Ideally suited for automatic insertion
- Complementary PNP types available (BC858x series)
- RoHS Compliant

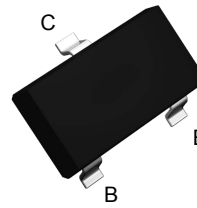

SOT-23

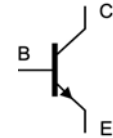

Schematic Diagram

Applications

- For switching and RF amplifier applications

Absolute Maximum Ratings ($T_A=25^{\circ}\text{C}$ unless otherwise noted)

Parameter	Symbol	Max.	Unit
Collector-Base Voltage	V_{CB0}	30	V
Collector-Emitter Voltage	V_{CEO}	30	V
Emitter-Base Voltage	V_{EB0}	6	V
Peak Collector Current	I_{CM}	200	mA
Collector Current-Continuous	I_C	100	mA
Collector Power Dissipation	P_C	200	mW
Typical Thermal Resistance from Junction to Ambient	$R_{\theta JA}$	410	$^{\circ}\text{C/W}$
Operating Junction Temperature Range	T_J	-55 To +150	$^{\circ}\text{C}$
Storage Temperature Range	T_{STG}	-55 To +150	$^{\circ}\text{C}$

Electrical Characteristics ($T_A=25^{\circ}\text{C}$ unless otherwise noted)

Parameter	Symbol	Conditions	Min.	Typ.	Max.	Unit
Collector-Base Cut-Off Current	I_{CBO}	$V_{CB}=30\text{V}, I_E=0$	-	-	15	nA
Emitter-Base Cut-Off Current	I_{EBO}	$V_{EB}=5\text{V}, I_C=0$	-	-	100	nA
DC Current Gain	h_{FE}	$V_{CE}=5\text{V}, I_C=2.0\text{mA}$	110	-	220	-
			200	-	450	-
			420	-	800	-
Collector-Emitter Saturation Voltage	$V_{CE(sat)}$	$I_C=10\text{mA}, I_B=0.5\text{mA}$	-	0.09	0.25	V
		$I_C=100\text{mA}, I_B=5.0\text{mA}$	-	0.2	0.6	V
Base-Emitter Saturation Voltage	$V_{BE(sat)}$	$I_C=10\text{mA}, I_B=0.5\text{mA}$	-	0.7	-	V
		$I_C=100\text{mA}, I_B=5.0\text{mA}$	-	0.9	-	V
Base-Emitter Voltage	V_{BE}	$V_{CE}=5\text{V}, I_C=2.0\text{mA}$	0.58	-	0.7	V
		$V_{CE}=5\text{V}, I_C=10\text{mA}$	-	-	0.75	V
Transition Frequency	f_T	$V_{CE}=5\text{V}, I_C=10\text{mA}, F=100\text{MHz}$	100	-	-	MHz
Collector Output Capacitance	C_{ob}	$V_{CB}=10\text{V}, I_E=0, F=1\text{MHz}$	-	2.5	4.5	pF

Classification of h_{FE}

h_{FE} Classification	BC848A	BC848B	BC848C
h_{FE} Range	110-220	200-450	420-800

Ratings and Characteristic Curves

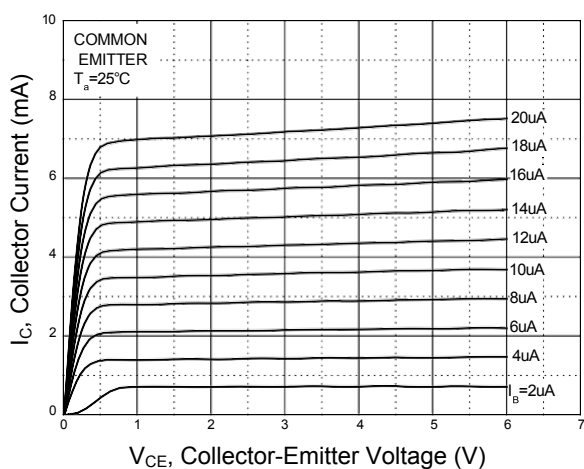

Figure 1. Static Characteristic

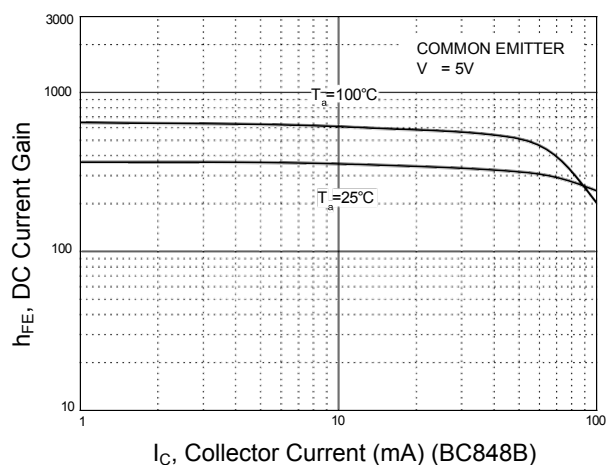

Figure 2. h_{FE} vs. Collector Current

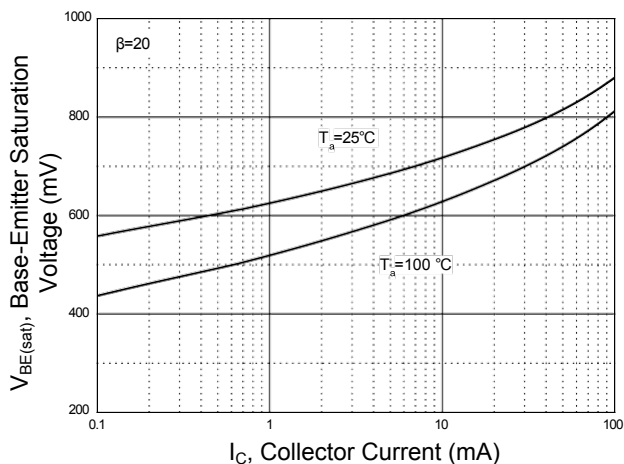

Figure 3. $V_{BE(sat)}$ vs. Collector Current

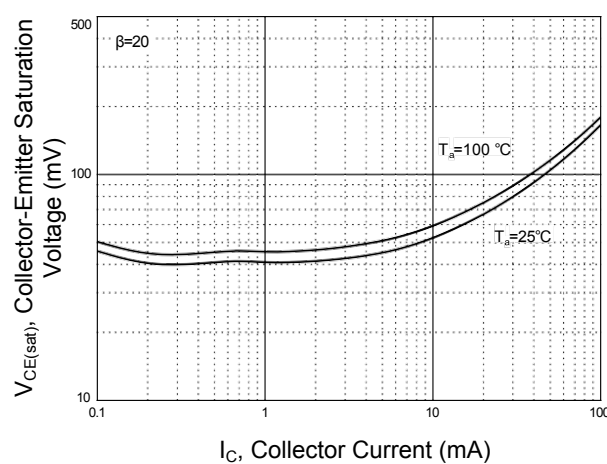

Figure 4. $V_{CE(sat)}$ vs. Collector Current

Ratings and Characteristic Curves

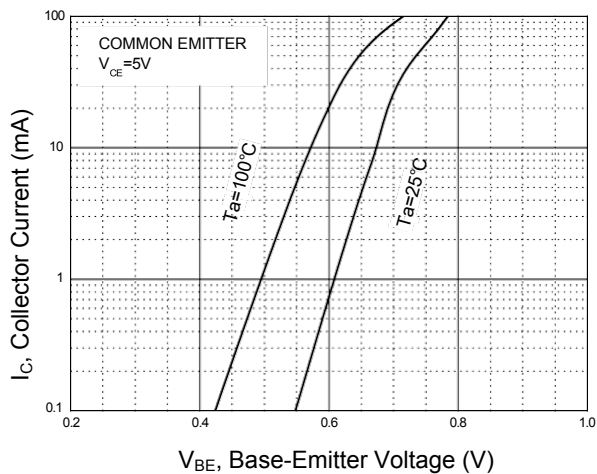

Figure 5. Collector Current vs. Base-Emitter Voltage

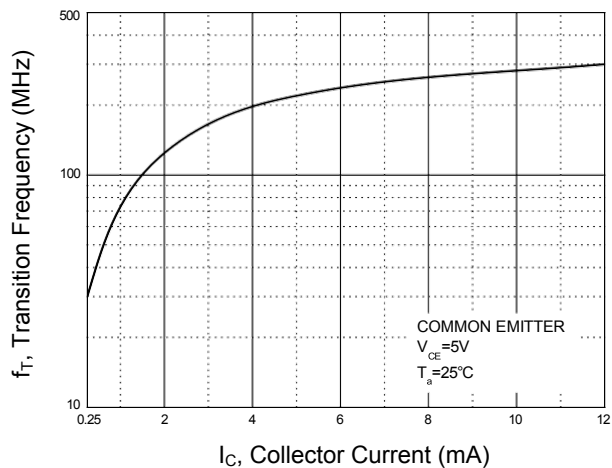

Figure 6. Transition Frequency vs. Collector Current

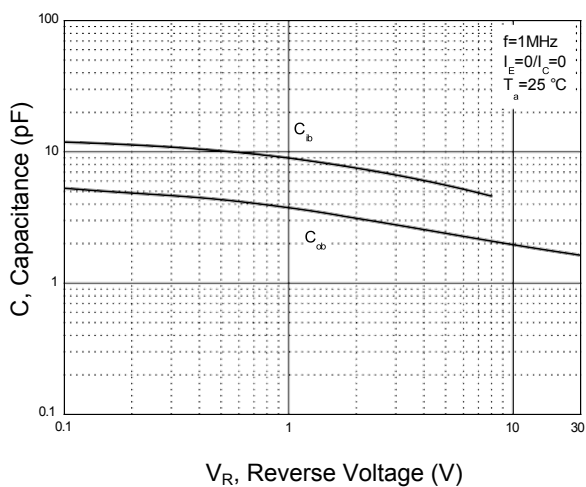

Figure 7. C_{ob}/C_{ib} vs. V_{CB}/V_{EB}

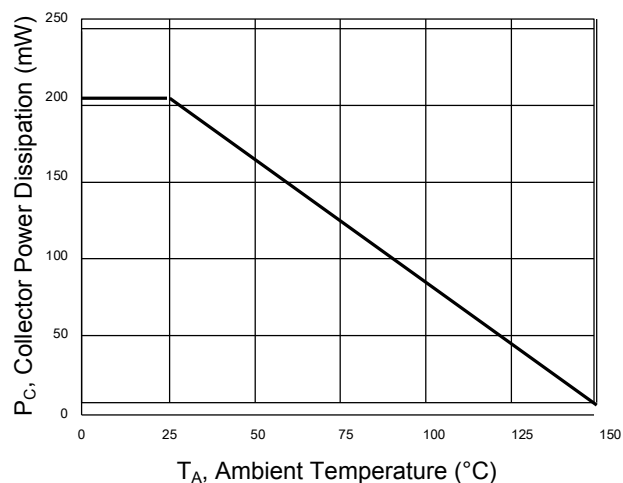
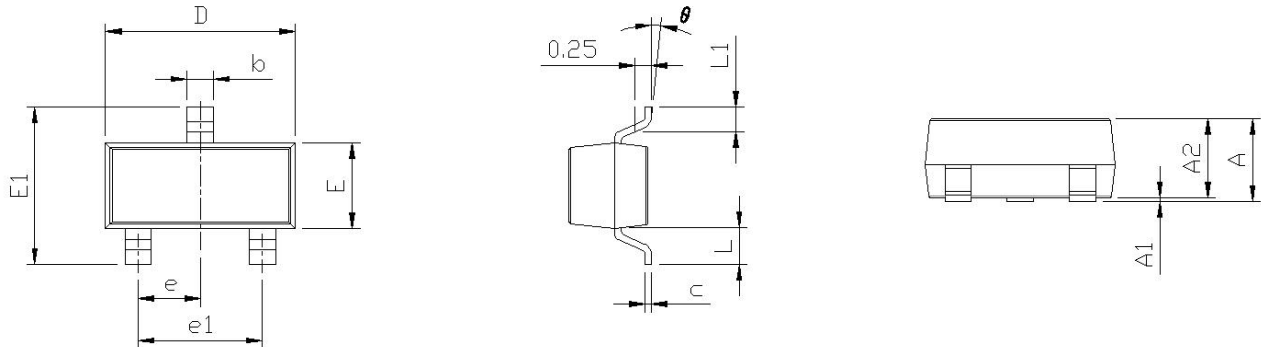

Figure 8. Collector Power Dissipation vs. T_A

Package Outline Dimensions (SOT-23)



Symbol	Dimensions in Millimeters		Dimensions in Inches	
	Min	Max	Min	Max
A	0.900	1.150	0.035	0.045
A1	0.000	0.100	0.000	0.004
A2	0.900	1.050	0.035	0.041
b	0.300	0.500	0.012	0.020
c	0.080	0.150	0.003	0.006
D	2.800	3.000	0.110	0.120
E	1.200	1.400	0.047	0.055
E1	2.250	2.550	0.089	0.100
e	0.950 TYP		0.037 TYP	
e1	1.800	2.000	0.071	0.079
L	0.550 REF		0.022 REF	
L1	0.300	0.500	0.012	0.020
θ	0°	8°	0°	8°

Recommended Pad Layout

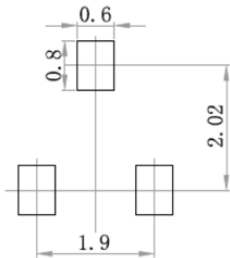

Note:

1. Controlling dimensions: in millimeters.
2. General tolerance: $\pm 0.05\text{mm}$.
3. The pad layout is for reference purposes only.

Order Information

Device	Package	Marking	Carrier	Quantity
BC848A	SOT-23	*1J	Tape & Reel	3,000pcs / Reel
BC848B	SOT-23	*1K	Tape & Reel	3,000pcs / Reel
BC848C	SOT-23	*1L	Tape & Reel	3,000pcs / Reel

Note: * is tracking code.

For more information, please contact us at: inquiry@goodarksemi.com