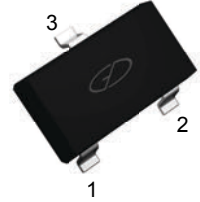


# BC846xW/BC847xW/BC848xW NPN Transistors

## Features

- Low current leakage
- Small surface mount package
- For high-speed switching applications
- Ideal for automatic insertion

1. BASE
2. EMITTER
3. COLLECTOR



**SOT-323**

## Maximum Ratings (T<sub>A</sub>=25°C unless otherwise specified)

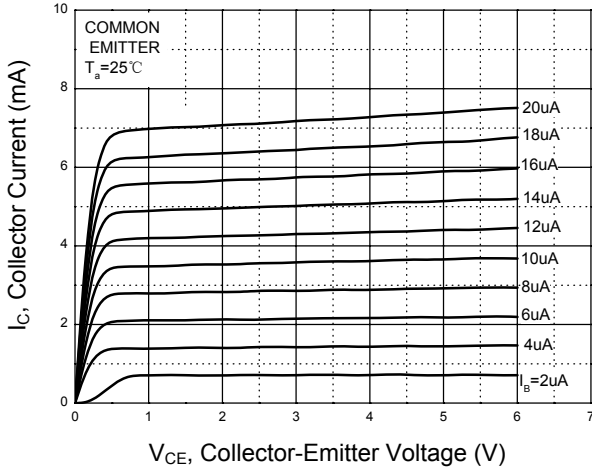
Parameter		Symbol	Value	Unit
Collector-Base Voltage	BC846W	V <sub>CBO</sub>	80	V
	BC847W		50	
	BC848W		30	
Collector-Emitter Voltage	BC846W	V <sub>CEO</sub>	65	V
	BC847W		45	
	BC848W		30	
Emitter-Base Voltage	BC846W	V <sub>EBO</sub>	6	V
	BC847W		6	
	BC848W		5	
Collector Current-Continuous		I <sub>C</sub>	0.1	A
Collector Power Dissipation		P <sub>C</sub>	150	mW
Thermal Resistance From Junction to Ambient		R <sub>θJA</sub>	833	°C/W
Junction Temperature		T <sub>J</sub>	-55 to +150	°C
Storage Temperature		T <sub>STG</sub>	-55 to +150	°C

## BC846xW/BC847xW/BC848xW NPN Transistors

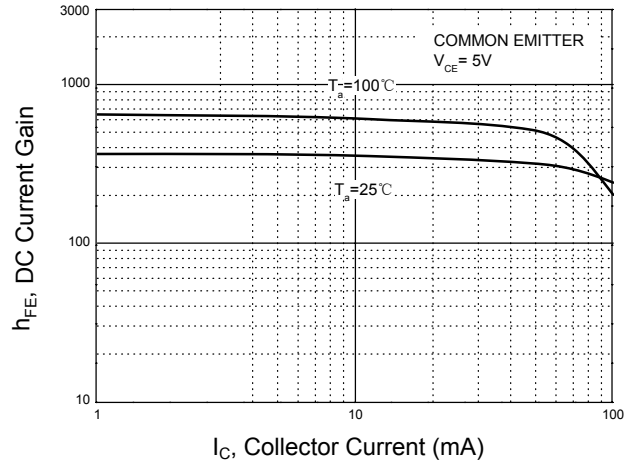
### Electrical Characteristics (T<sub>A</sub>=25°C unless otherwise specified)

Parameter		Symbol	Test Conditions	Min	Typ	Max	Unit
Collector-Base Breakdown Voltage	BC846xW	V <sub>CBO</sub>	I <sub>C</sub> =10μA, I <sub>E</sub> =0	80	-	-	V
	BC847xW			50			
	BC848xW			30			
Collector-Emitter Breakdown Voltage	BC846xW	V <sub>CEO</sub>	I <sub>C</sub> =10mA, I <sub>B</sub> =0	65	-	-	V
	BC847xW			45			
	BC848xW			30			
Emitter-Base Breakdown Voltage	BC846xW	V <sub>EBO</sub>	I <sub>E</sub> =1μA, I <sub>C</sub> =0	6	-	-	V
	BC847xW			6			
	BC848xW			5			
Collector Cutoff Current		I <sub>CBO</sub>	V <sub>CB</sub> =30V, I <sub>E</sub> =0	-	-	15	nA
DC Current Gain	BC846AW, BC847AW, BC848AW	h <sub>FE</sub>	V <sub>CE</sub> =5V, I <sub>C</sub> =10μA	-	90	-	-
	BC846BW, BC847BW, BC848BW			-	150	-	
	BC847CW, BC848CW			-	270	-	
	BC846AW, BC847AW, BC848AW		V <sub>CE</sub> =5V, I <sub>C</sub> =2mA	110	-	220	
	BC846BW, BC847BW, BC848BW			200	-	450	
	BC847CW, BC848CW			420	-	800	
Collector-Emitter Saturation Voltage		V <sub>CE(sat)</sub>	I <sub>C</sub> =10mA, I <sub>B</sub> =0.5mA I <sub>C</sub> =100mA, I <sub>B</sub> =5mA	-		0.25 0.6	V
Base-Emitter Saturation Voltage		V <sub>BE(sat)</sub>	I <sub>C</sub> =10mA, I <sub>B</sub> =0.5mA I <sub>C</sub> =100mA, I <sub>B</sub> =5mA	-	0.7 0.9	-	V
Base-Emitter Voltage		V <sub>BE(on)</sub>	V <sub>CE</sub> =5V, I <sub>C</sub> =2mA V <sub>CE</sub> =5V, I <sub>C</sub> =10mA	580 -	660 -	700 770	mV
Transition Frequency		f <sub>T</sub>	V <sub>CE</sub> =5V, I <sub>C</sub> =10mA F=100MHz	100	-	-	MHz
Collector Output Capacitance		C <sub>ob</sub>	V <sub>CB</sub> =10V, F=1MHz	-	-	4.5	pF
Noise Figure	BC846AW, BC847AW, BC848AW	N <sub>F</sub>	V <sub>CE</sub> =5V, I <sub>C</sub> =0.2mA	-	-	10	dB
	BC846BW, BC847BW, BC848BW		F=1kHz, R <sub>S</sub> =2kΩ	-	-	10	
	BC847BW, BC848BW		BW=200Hz	-	-	4	

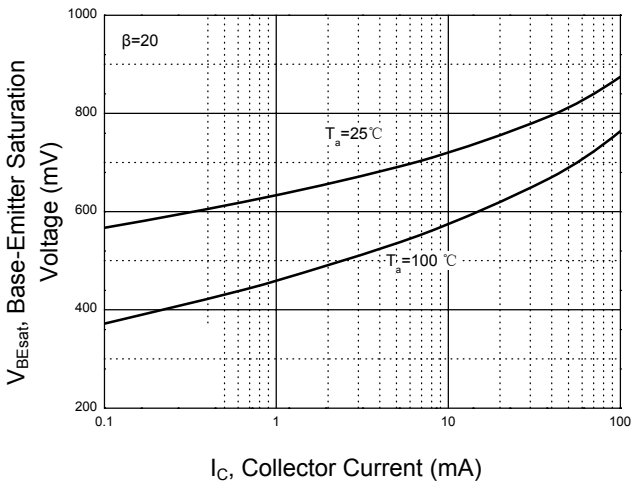
**Typical Characteristic Curves**



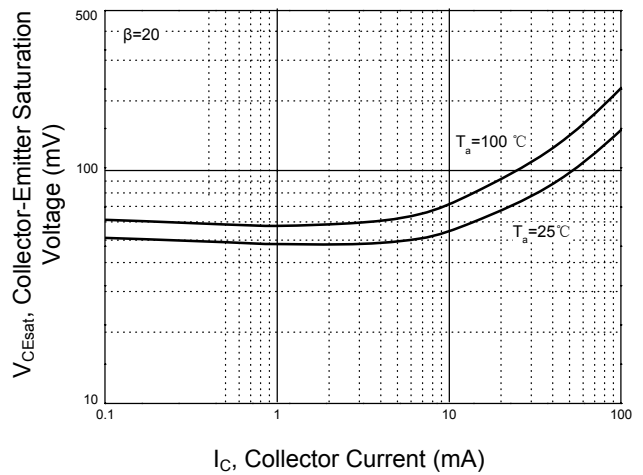
**Figure 1. Static Characteristic**



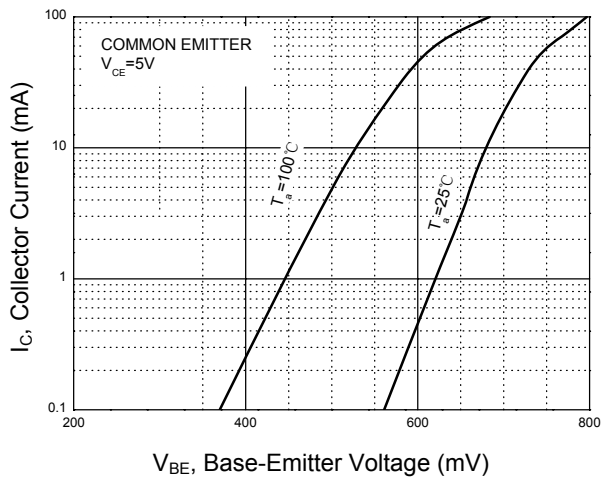
**Figure 2.  $h_{FE} - I_C$**



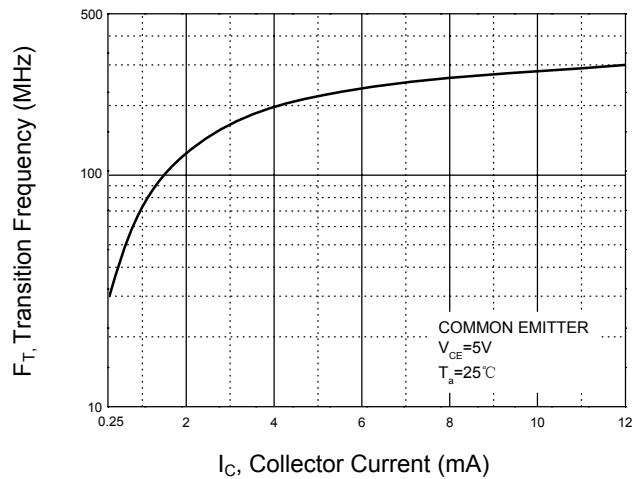
**Figure 3.  $V_{BE(sat)} - I_C$**



**Figure 4.  $V_{CE(sat)} - I_C$**

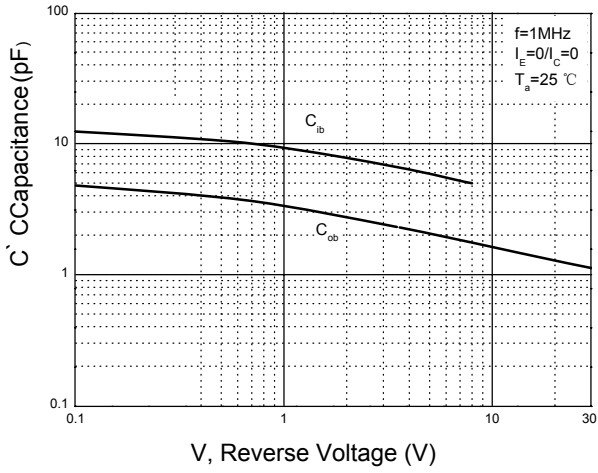


**Figure 5.  $I_C - V_{BE}$**

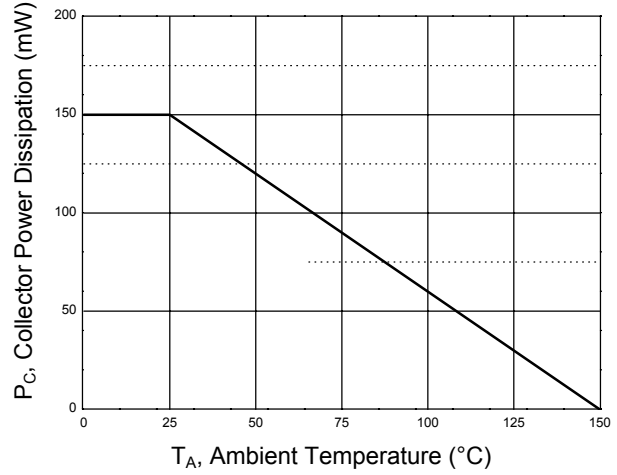


**Figure 6.  $F_T - I_C$**

**Typical Characteristic Curves**



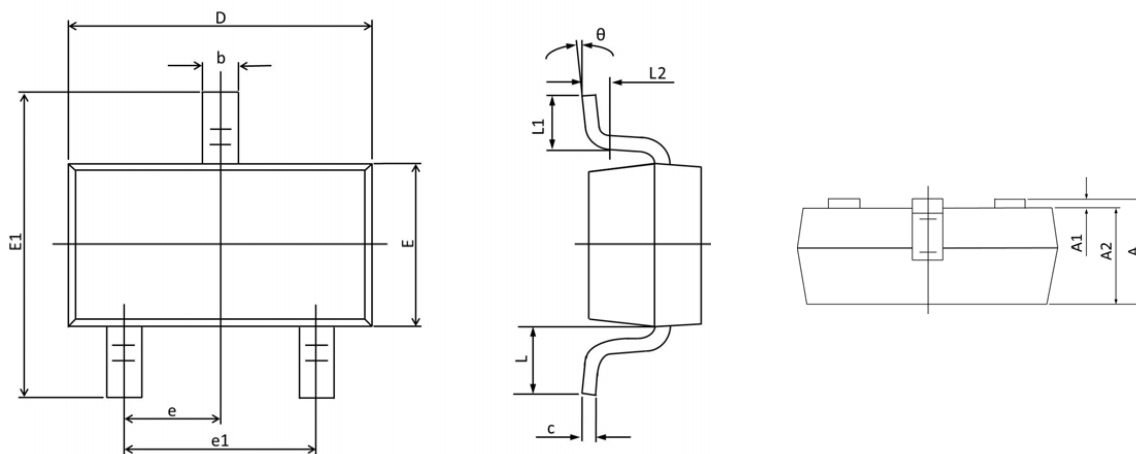
**Figure 7.  $C_{ob}/C_{ib} - V_{CB}/V_{EB}$**



**Figure 8.  $P_C - T_A$**

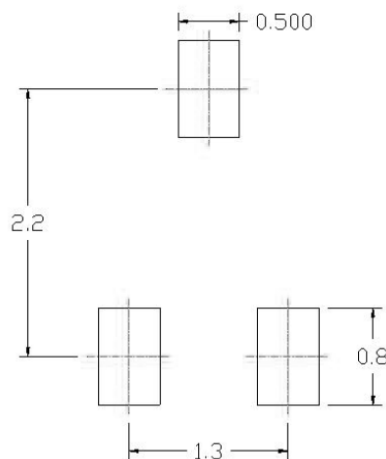
## BC846xW/BC847xW/BC848xW NPN Transistors

### Package Outline Dimensions (SOT-323)



Symbol	Dimensions In Millimeters		Dimensions In Inches	
	Min.	Max.	Min.	Max.
A	0.900	1.100	0.035	0.045
A1	0.000	0.100	0.000	0.004
A2	0.900	1.000	0.035	0.039
b	0.200	0.400	0.008	0.016
c	0.080	0.150	0.003	0.006
D	2.000	2.200	0.079	0.087
E	1.150	1.350	0.045	0.053
E1	2.150	2.450	0.085	0.096
e	0.650 TYP.		0.026 TYP.	
e1	1.200	1.400	0.047	0.055
L	0.525 REF.		0.021 REF.	
L1	0.260	0.460	0.010	0.018
L2	0.20 REF.		0.008 REF.	
θ	0°	8°	0°	8°

### Recommended Pad Layout



**Note:**

1. Controlling dimension: in millimeters
2. General tolerance:  $\pm 0.05\text{mm}$
3. The pad layout is for reference purposes only

### Order Information

Device	Package	Marking	Carrier	Quantity
BC846AW	SOT-323	1A	Tape & Reel	3,000pcs / 7" Reel
BC846BW	SOT-323	1B	Tape & Reel	3,000pcs / 7" Reel
BC847AW	SOT-323	1E	Tape & Reel	3,000pcs / 7" Reel
BC847BW	SOT-323	1F	Tape & Reel	3,000pcs / 7" Reel
BC847CW	SOT-323	1G	Tape & Reel	3,000pcs / 7" Reel
BC848AW	SOT-323	1J	Tape & Reel	3,000pcs / 7" Reel
BC848BW	SOT-323	1K	Tape & Reel	3,000pcs / 7" Reel
BC848CW	SOT-323	1L	Tape & Reel	3,000pcs / 7" Reel