

MUR2020CT/ MUR2020FCT

Super Fast Recovery Planar Rectifier
 Reverse Voltage 200V Forward Current 20A

Unit: millimeters

TO-220-AB

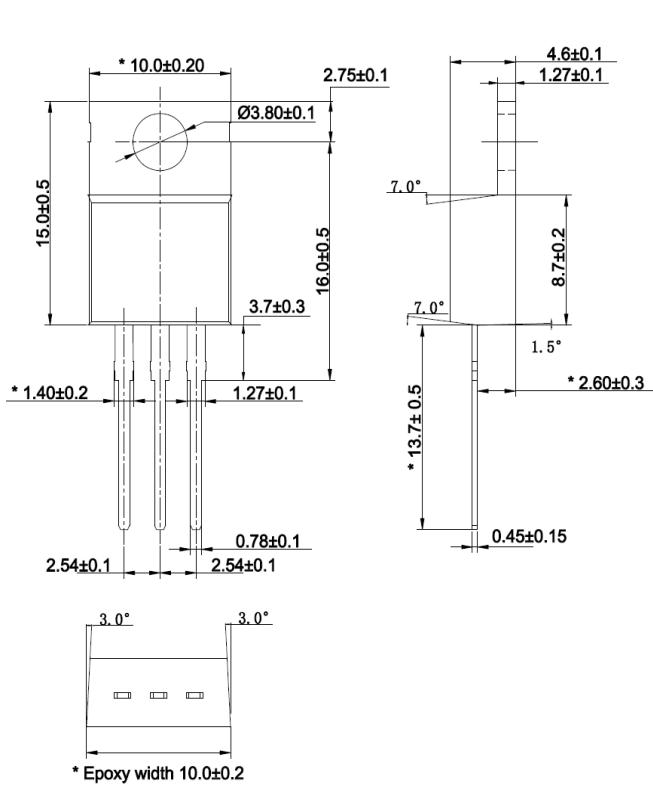

ITO-220--AB

