

Features

- Plastic package has Underwriters Laboratory Flammability Classification 94V-0
- Fast switching for high efficiency
- Low forward voltage drop
- Dual rectifiers construction
- High surge capability
- High temperature soldering guaranteed: 260°C/10 seconds
- Component in accordance to RoHS 2015/863/EU

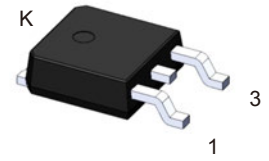

TO-252

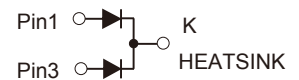

Mechanical Data

- Case: JEDEC TO-252(DPAK) molded plastic body
- Terminals: Solderable per MIL-STD-202, method 208
- Polarity: As marked

Applications

- For use in boost stage in SMPS
- High frequency inverters for solar inverters
- DC/DC converters
- High frequency output rectification of battery chargers
- Free wheeling diodes in motor drivers

Maximum Ratings (Ratings at 25°C ambient temperature unless otherwise specified, single phase, half wave, resistive or inductive load. For capacitive load, derate by 20%.)

Parameters	Symbol	Value	Unit
Maximum Repetitive Peak Reverse Voltage	V_{RRM}	200	V
Maximum Average Forward Rectified Current	$I_{F(AV)}$	6.0	A
Peak Forward Surge Current 8.3ms Single Half Sine-wave Superimposed on Rated Load (JEDEC Method, Per Leg)	I_{FSM}	60	A
Rating for Fusing (t=8.3ms)	I^2t	14.94	A ² S
Operating Junction Temperature Range	T_J	-55 to 150	°C
Storage Temperature Range	T_{stg}	-55 to 150	°C

Electrical Characteristics

 (Per Leg, $T_A=25^\circ\text{C}$ unless otherwise noted)

Parameter	Test Conditions		Symbol	Typ.	Max.	Unit
Instantaneous Forward Voltage ¹	$I_F=3.0\text{A}$	$T_J=25^\circ\text{C}$	V_F	0.87	0.93	V
		$T_J=125^\circ\text{C}$		0.68	-	
Reverse Current ²	$V_R=200\text{V}$	$T_J=25^\circ\text{C}$	I_R	-	5.0	μA
		$T_J=125^\circ\text{C}$		-	50	
Typical Junction Capacitance	4V, 1MHz		C_J	43		pF
Reverse Recovery Time ³	$I_F=0.5\text{A}, I_R=1\text{A}, I_{RR}=0.25\text{A}$		t_{rr}	17	25	nS

Notes:

1. Pulse test: 300 μs pulse width, 1% duty cycle
2. Pulse test: pulse width $\leq 40\text{ms}$
3. $T_J=25^\circ\text{C}$

Thermal Characteristics

Parameter	Symbol	TO-252	Unit
Typical Thermal Resistance, Junction to Case	$R_{\theta JC}$	2.5	°C/W

Ratings and Characteristics Curves

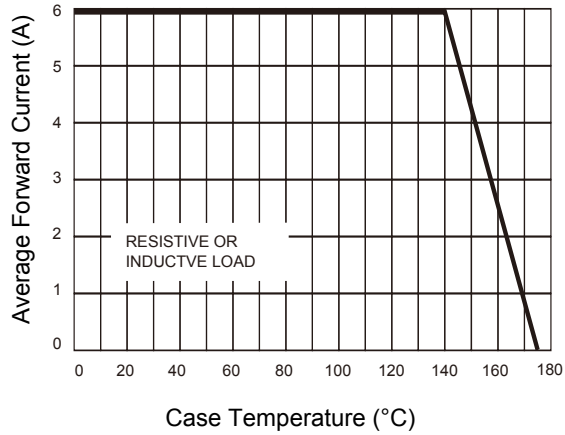

Figure 1. Forward Current Derating Curve

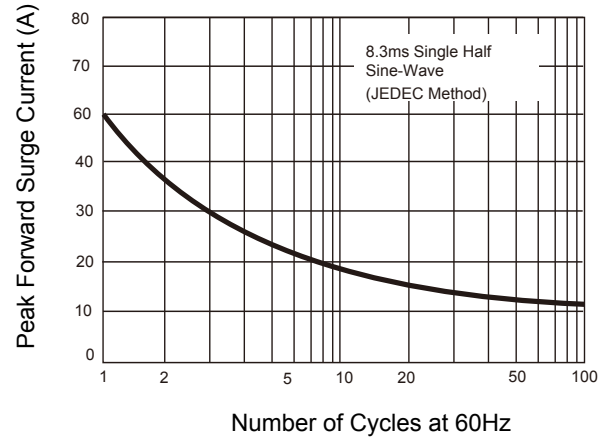

Figure 2. Maximum Non-Repetitive Forward Surge Current

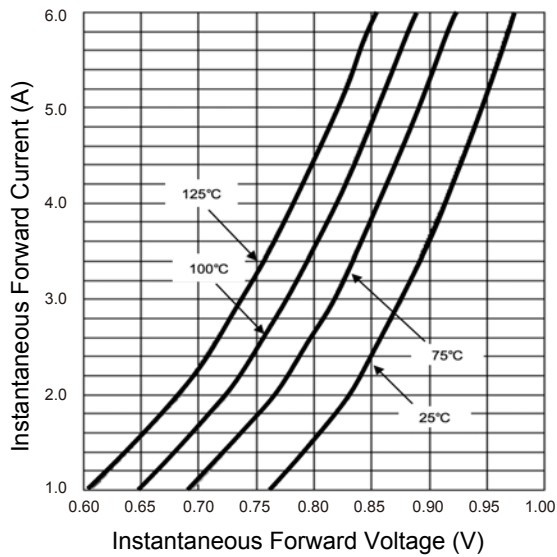

Figure 3. Typical Instantaneous Forward Characteristics

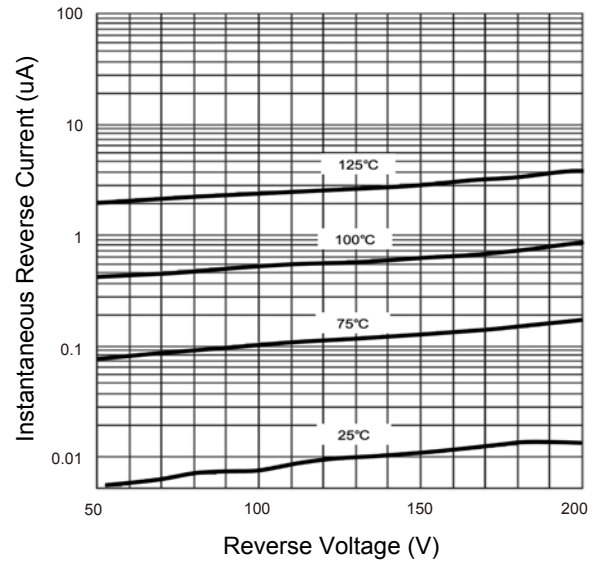
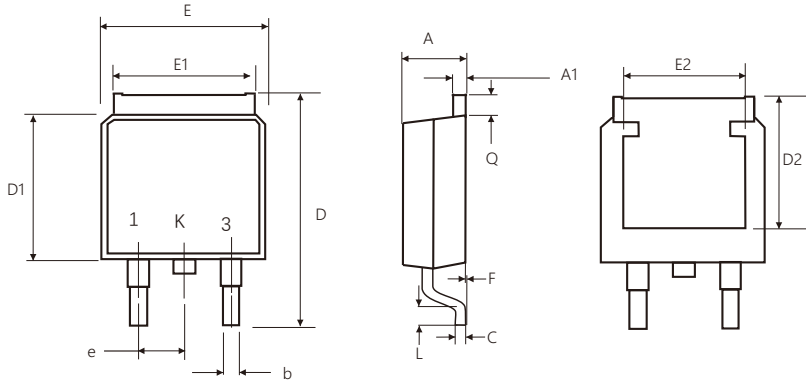

Figure 4. Typical Reverse Characteristics

Package Outline Dimensions (TO-252)



Symbol	Dimensions In Millimeters		Dimensions In Inches	
	Min.	Max.	Min.	Max.
A	2.15	2.65	0.085	0.104
A1	0.42	0.58	0.017	0.023
e	2.14	2.40	0.084	0.094
b	0.64	0.89	0.025	0.035
Q	0.88	1.27	0.035	0.050
C	0.42	0.58	0.017	0.023
D	9.00	10.41	0.354	0.410
D1	5.60	6.22	0.220	0.245
E	6.20	6.73	0.244	0.265
E1	5.21	5.46	0.205	0.215
L	1.00	-	0.039	-
F	0.01	0.11	0.000	0.004
D2	5.11	5.58	0.201	0.220
E2	4.31	5.33	0.170	0.210

Recommended Pad Layout

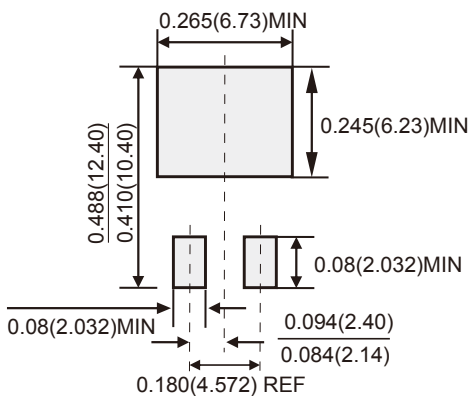

Note:

1. Unit in inches (millimeters)
2. Pad layout for reference

For more information, please contact us at: inquiry@goodarksemi.com