

MBRH20150S/MBRFH20150S

Schottky Barrier Rectifier
 Reverse Voltage 150 V Forward Current 20 A

Features

- Plastic package has underwriters Laboratory Flammability Classification 94V-0
- Low forward voltage, high efficiency



MBRH20150S
 Package: TO-220-AB

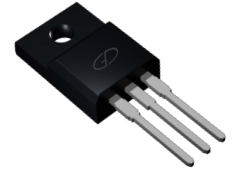

MBRFH20150S
 Package: ITO-220-AB

Mechanical Data

- Case: epoxy, molded
- Weight: 1.9grams (approximately)
- Lead temperature for soldering purpose: 260°C max. for 10 sec
- 50 units per plastic tube

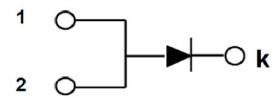

Schematic Diagram

Maximum Ratings & Electrical Characteristics

($T_A=25^\circ\text{C}$ unless otherwise noted)

Parameter	Test Conditions		Symbol	Value	Unit
Maximum Repetitive Peak Reverse Voltage			V_{RRM}	150	V
Working Peak Reverse Voltage			V_{RWM}	150	V
Maximum DC Blocking Voltage			V_{DC}	150	V
Maximum Average Forward Rectified Current @ $T_c=105^\circ\text{C}$	Total Device		$I_{F(AV)}$	20	A
Peak Forward Surge Current 8.3ms Single Half Sine-wave Superimposed on Rated Load per Diode			I_{FSM}	150	A
Peak repetitive Reverse Current Per Leg at $t_p=2.0\mu\text{s}$, 1KHz			I_{RRM}	1.0	A
Voltage Rate of Change (rated V_R)			DV/dt	10000	V/ μs
Operating Junction Temperature Range			T_J	- 55 to+150	$^\circ\text{C}$
Storage Temperature Range			T_{STG}	- 55 to+150	$^\circ\text{C}$
Isolation Voltage (ITO-220-AB only) from Terminal to Heatsink $t = 1 \text{ sec}$			V_{AC}	1500	V
Maximum Instantaneous Forward Voltage per Leg	$I_F=10\text{A}$	$T_c=25^\circ\text{C}$	V_F	0.83	V
	$I_F=10\text{A}$	$T_c=125^\circ\text{C}$		0.73	
Maximum Reverse Current per Leg at Working Peak Reverse Voltage			I_R	500	μA
				50	mA

Thermal Characteristics ($T_A=25^\circ\text{C}$ unless otherwise noted)

Symbol	Parameter	Typ.(TO-220-AB)	Typ.(ITO-220-AB)	Unit
$R_{\theta JC}$	Thermal Resistance, Junction to Case per Leg	2.0	4.0	$^\circ\text{C/W}$
$R_{\theta JA}$	Thermal Resistance, Junction to Ambient per Leg	62.5	62.5	$^\circ\text{C/W}$

Note: Pulse test:300us pulse width, duty cycle=2%

Ratings and Characteristics Curves ($T_A = 25^\circ\text{C}$ unless otherwise noted)

FIG.1- FORWARD CURRENT DERATING CURVE

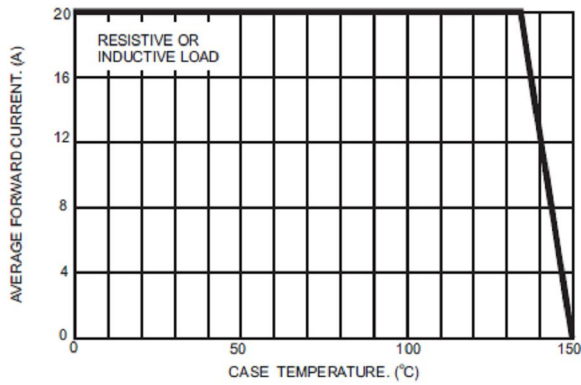

FIG.2- MAXIMUM NON-REPETITIVE FORWARD SURGE CURRENT PER LEG

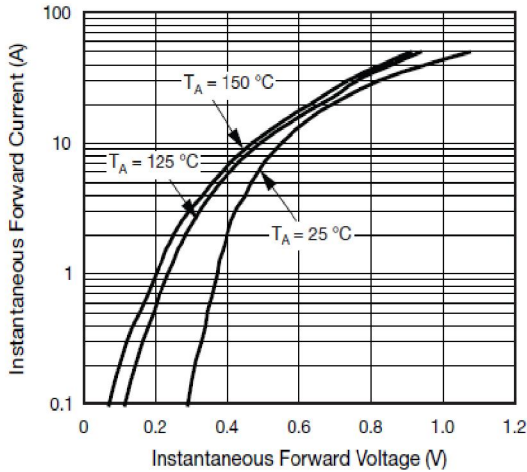
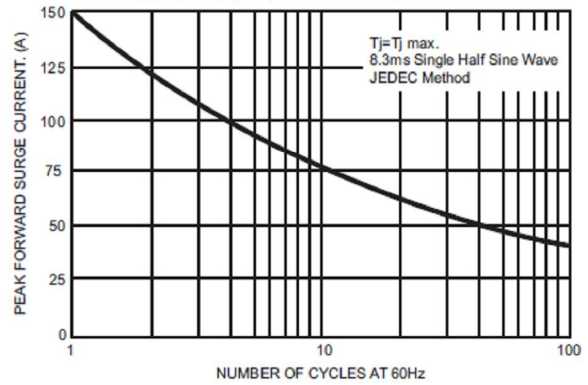

Fig. 3 - Typical Instantaneous Forward Characteristics

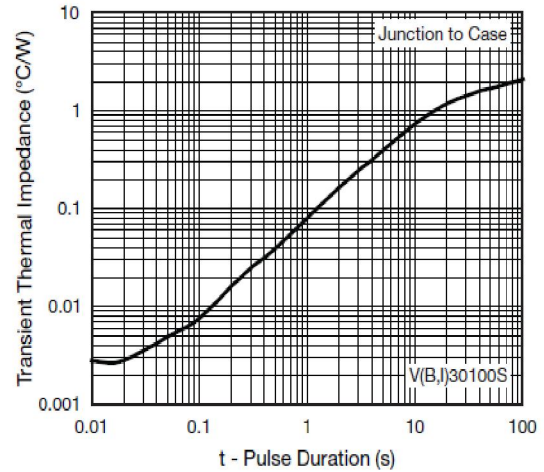

Fig. 4 Typical Transient Thermal Impedance

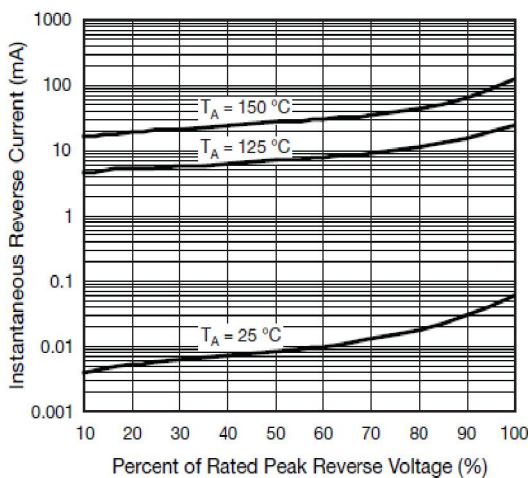

Fig 5 Typical Reverse Characteristics

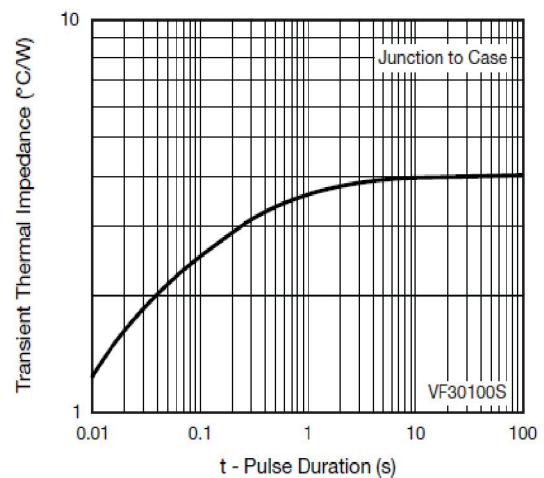
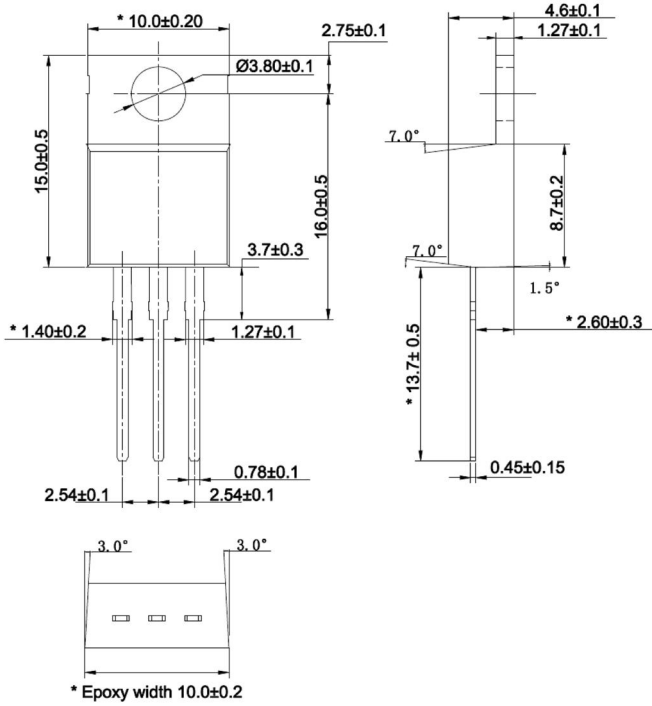

Fig.6 Typical Transient Thermal Impedance

Package Outline Dimensions

in millimeters

TO-220-AB



ITO-220-AB

