

Features

- Power pack
- Metal silicon junction, majority carrier conduction
- Guard ring for overvoltage protection
- Low power loss, high efficiency
- High current capability, low forward voltage drop
- High forward surge capability
- High frequency operation
- Solder bath temperature 275°C maximum, 10s, per JESD22-B106
- Component in accordance to RoHS 2015/863/EU

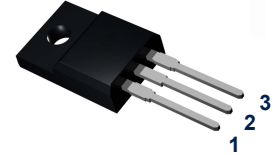

ITO-220AB

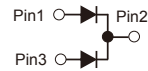

Schematic Diagram

Mechanical Data

- Case: JEDEC ITO-220AB
- Molding compound meets UL 94V-0 flammability rating
- Terminals: Lead solderable per J-STD-002 and JESD22-B102
- Polarity: As marked
- Mounting torque: 10 in-lbs maximum

Maximum Ratings (Ratings at 25°C ambient temperature unless otherwise specified)

Parameter	Symbol	Value	Unit
Maximum Repetitive Peak Reverse Voltage	V_{RRM}	45	V
Maximum Average Forward Rectified Current, $D=0.5$, Square Waveform, $T_C \leq 108^\circ\text{C}$ (See Fig.1)	Per Leg	15.0	A
	Total Device	30.0	
Peak Forward Surge Current 8.3ms Single Half Sine-Wave Superimposed on Rated Load (JEDEC Method at Rated T_L), Total Device	I_{FSM}	300	A
Peak Repetitive Reverse Current at $t_p=2\mu\text{s}$ 1KHz	I_{RRM}	0.5	A
Isolation Voltage from Terminals to Heatsink $t=1\text{min}$	V_{AC}	1500	V
Typical Thermal Resistance, Junction to Case ¹	$R_{\theta JC}$	3.2	$^\circ\text{C}/\text{W}$
Operating Junction and Storage Temperature Range	T_J, T_{STG}	-55 to +150	$^\circ\text{C}$

Electrical Characteristics ($T_A=25^\circ\text{C}$ unless otherwise noted)

Parameter	Symbol	Test Conditions	Typ.	Max.	Unit	
Instantaneous Forward Voltage ²	V_F	$I_F=15.0\text{A}$	$T_A=25^\circ\text{C}$	0.49	0.52	V
			$T_A=100^\circ\text{C}$	0.43	-	
			$T_A=125^\circ\text{C}$	0.41	-	
		$I_F=10.0\text{A}$	$T_A=25^\circ\text{C}$	0.43	0.45	
			$T_A=100^\circ\text{C}$	0.37	-	
			$T_A=125^\circ\text{C}$	0.35	-	
Reverse Current ³	I_R	$V_R=45\text{V}$	$T_A=25^\circ\text{C}$	100	200	μA
			$T_A=100^\circ\text{C}$	8	15	mA
			$T_A=125^\circ\text{C}$	20	50	
Typical Junction Capacitance	C_J	4V, 1MHz	570		pF	

Notes:

1. Thermal resistance from junction to case, total device
2. Pulse test: 300us pulse width, 1% duty cycle
3. Pulse test: pulse width $\leq 40\text{ms}$

Ratings and Characteristics Curves

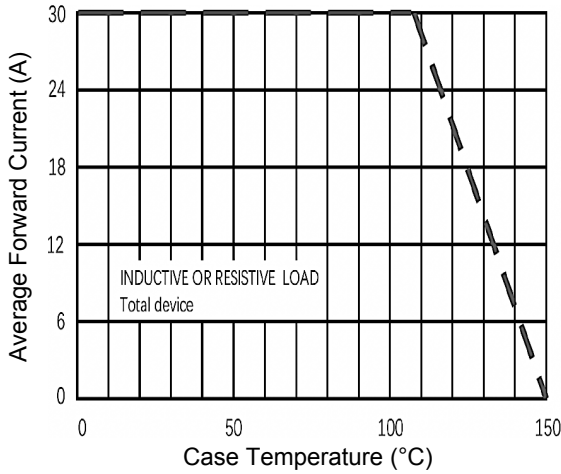

Figure 1. Forward Current Derating Curve

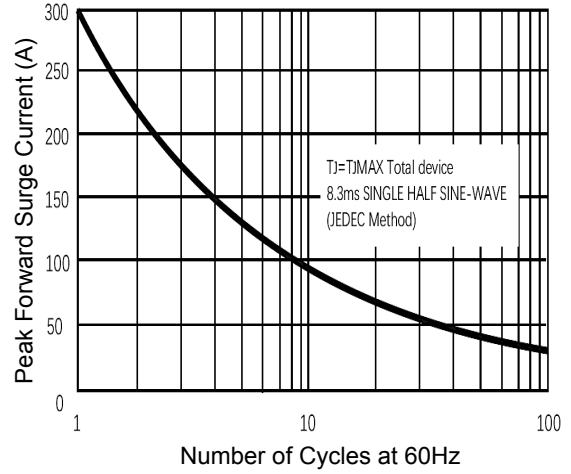

Figure 2. Maximum Non-Repetitive Peak Forward Surge Current

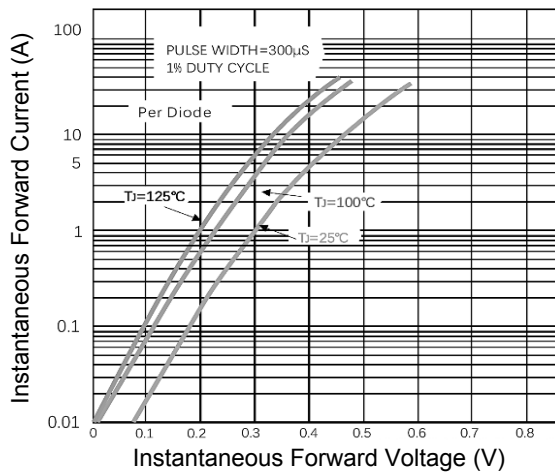

Figure 3. Typical Instantaneous Forward Characteristics

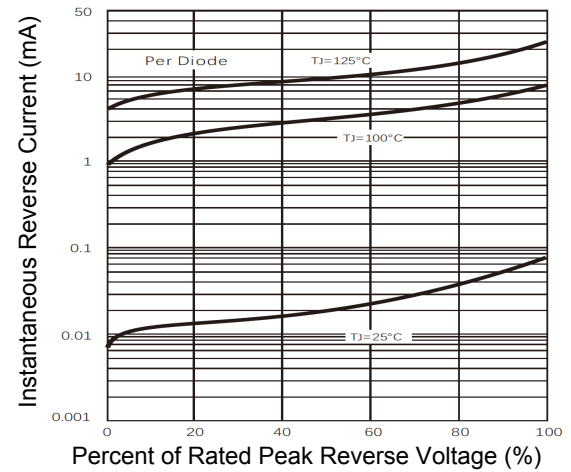

Figure 4. Typical Reverse Characteristics

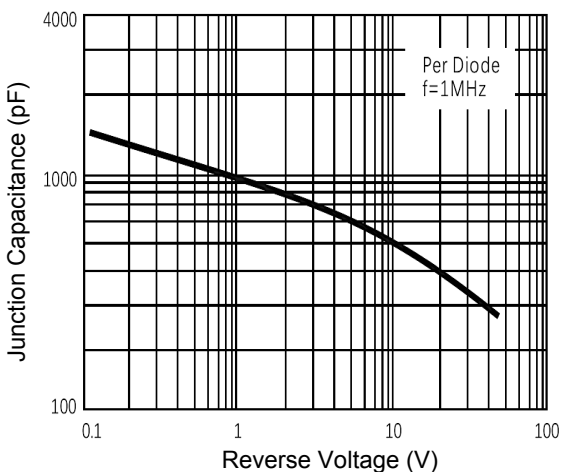
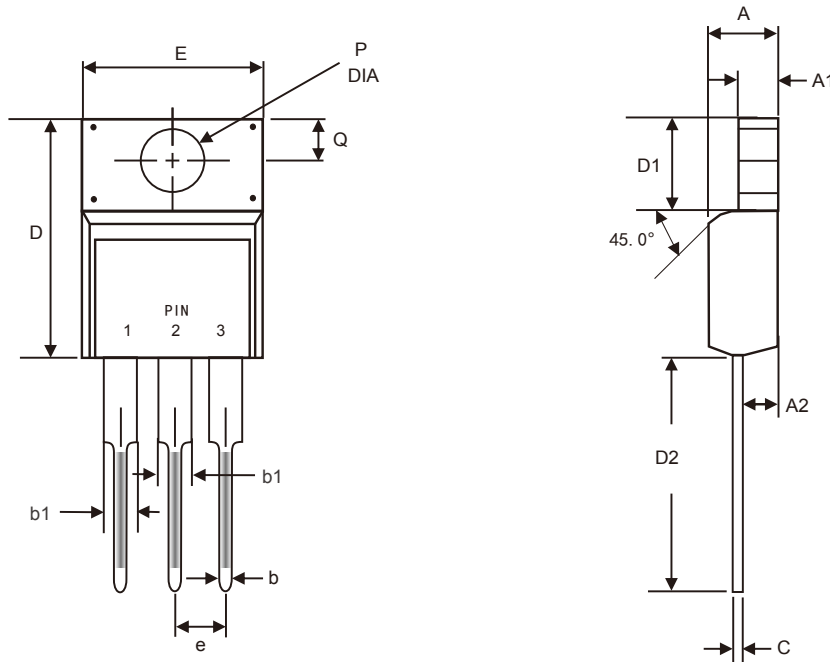

Figure 5. Typical Junction Capacitance

Package Outline Dimensions (ITO-220AB)



Symbol	Dimensions in Millimeters		Dimensions in Inches	
	Min.	Max.	Min.	Max.
A	4.49	4.89	0.177	0.192
A1	2.28	2.88	0.090	0.113
A2	2.50	2.90	0.098	0.114
b	0.67	0.93	0.026	0.037
b1	1.10	1.43	0.043	0.056
C	0.37	0.63	0.015	0.025
D	15.40	16.40	0.606	0.646
D1	6.45	6.85	0.254	0.270
D2	12.50	13.50	0.492	0.531
e	2.44	2.64	0.096	0.104
E	9.91	10.41	0.390	0.410
Q	3.05	3.45	0.120	0.136
P	3.15	3.45	0.124	0.132

Order Information

Device	Package	Marking	Carrier	Quantity
GSRF3045LCT	ITO-220AB	SRF3045LCT	Tube	50 Pcs / Tube