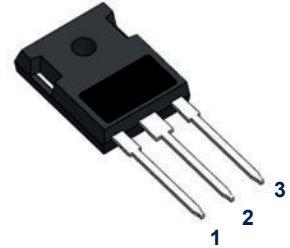
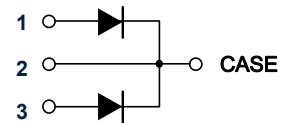


## Features

- Plastic package has underwriters laboratory flammability classification 94V-0
- Metal silicon junction, majority carrier conduction
- Guard ring for over voltage protection
- Low power loss, high efficiency
- High current capability, low forward voltage drop
- High surge capability
- For use in low voltage, high frequency inverters, free wheeling and polarity protection applications
- Dual rectifier construction
- High temperature soldering guaranteed: 260°C /10 seconds, 0.25" (6.35mm) from case
- Component in accordance to 2015/863/EU



TO-247AB



Schematic Diagram

## Mechanical Data

- Case: TO-247AB molded plastic body
- Terminals: Lead solderable per MIL-STD-750, method 2026
- Polarity: As marked
- Mounting position: Any

## Maximum Ratings and Electrical Characteristics

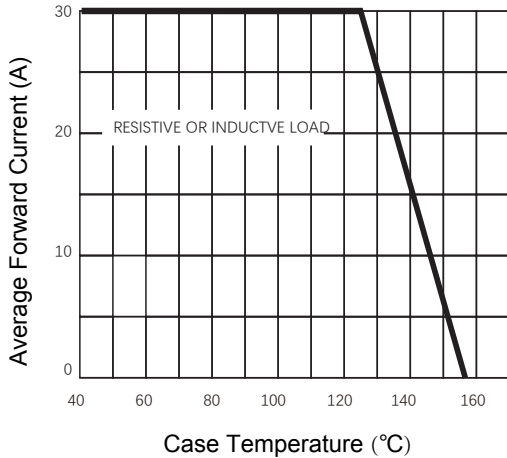
(Ratings at 25°C ambient temperature unless otherwise specified)

Parameters		Symbols	Value				Unit
Maximum Recurrent Peak Reverse Voltage		$V_{RRM}$	200				V
Maximum RMS Voltage		$V_{RMS}$	141				V
Maximum DC Blocking Voltage		$V_{DC}$	200				V
Maximum Average Forward Rectified Current (see Fig.1)	Per leg	$I_{F(AV)}$	15.0				A
	Total device		30.0				
Peak Forward Surge Current 8.3ms Single Half Sine-Wave Superimposed on Rated Load (JEDEC Method)		$I_{FSM}$	250				A
Forward Voltage at 15A Per Leg <sup>1</sup>		$V_F$	Typ.	0.83	Max.	0.90	V
Maximum Instantaneous Reverse Current at Rated DC Blocking Voltage <sup>1</sup>	$T_J=25^\circ\text{C}$	$I_R$	Typ.	-	Max.	10	uA
	$T_J=125^\circ\text{C}$		Typ.	-	Max.	10	mA
Typical Thermal Resistance <sup>2</sup>		$R_{\theta JC}$	1.5				°C/W
Operating Junction Temperature Range		$T_J$	-55 to +150				°C
Storage Temperature Range		$T_{STG}$	-55 to +150				°C

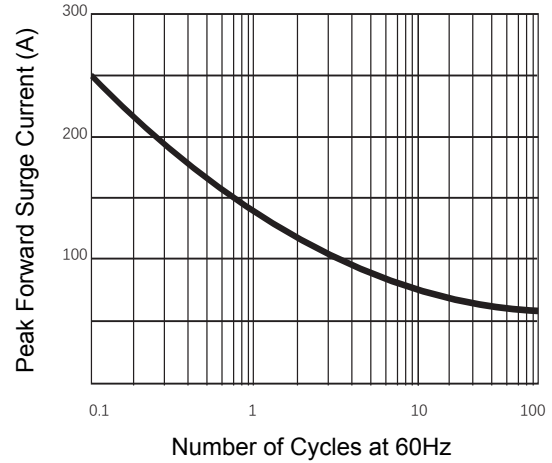
Notes:

1. Pulse test: 300 us pulse width, 1% duty cycle.
2. Thermal resistance from junction to case.

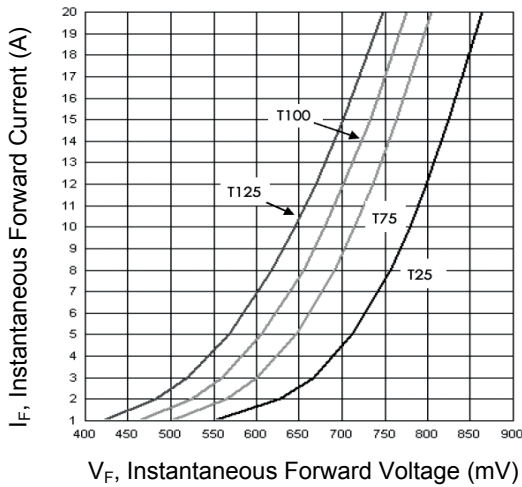
## Ratings and Characteristic Curves



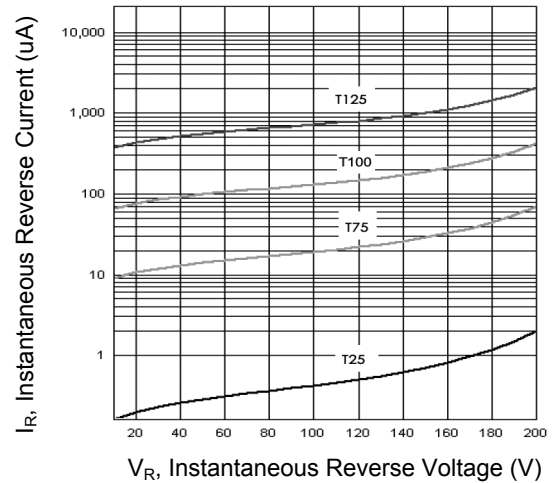
**Figure 1. Forward Current Derating Curve**



**Figure 2. Max. Non-Repetitive Peak Forward Surge Current**

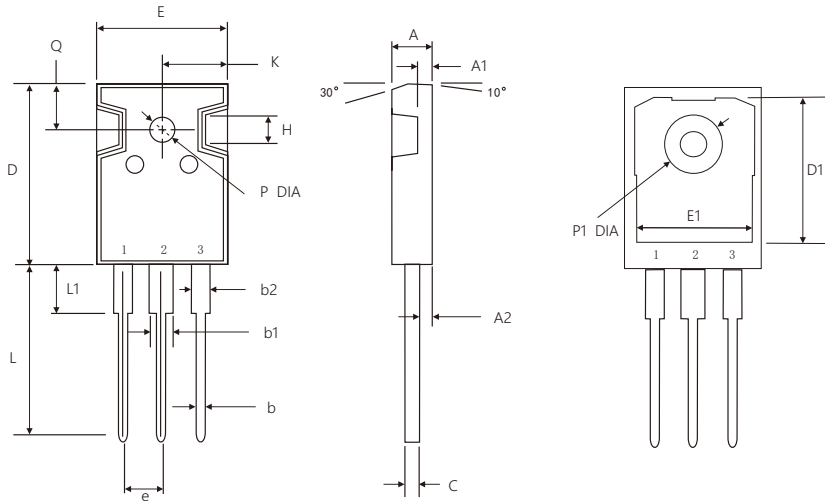


**Figure 3. Typical Instantaneous Forward Characteristics**



**Figure 4. Typical Reverse Characteristics**

## Package Outline Dimensions (TO-247AB)



Symbol	Dimensions In Millimeters		Dimensions In Inches	
	Min.	Max.	Min.	Max.
A	4.70	5.30	0.185	0.209
A1	1.80	2.20	0.071	0.087
A2	2.24	2.58	0.088	0.102
b	1.00	1.40	0.039	0.055
b1	2.60	3.60	0.102	0.142
b2	1.60	2.60	0.063	0.102
C	0.40	0.80	0.016	0.031
D	20.00	22.00	0.787	0.866
D1	16.25	16.85	0.640	0.663
E	15.4	16.4	0.606	0.646
E1	13.10	13.50	0.516	0.531
L	19.60	20.40	0.772	0.803
e	5.20	5.70	0.205	0.224
L1	3.80	4.50	0.150	0.177
P	3.30	3.70	0.130	0.146
P1	-	7.30	-	0.287
Q	5.40	6.40	0.213	0.252
K	7.40	8.20	0.291	0.323
H	4.60 TYP		0.181 TYP	

## Order Information

Device	Package	Marking	Carrier	Quantity
GSR30200PT	TO-247AB	SR30200PT	Tube	30pcs / Tube

For more information, please contact us at: [inquiry@goodarksemi.com](mailto:inquiry@goodarksemi.com)