

Features

- Plastic package has Underwriters Laboratory Flammability Classification 94V-0
- Metal silicon junction, majority carrier conduction
- Guard ring for over-voltage protection
- Low power loss, high efficiency
- High current capability, low forward voltage drop
- For use in low voltage, high frequency inverters, free wheeling, and polarity protection applications
- Dual rectifier construction
- High temperature soldering guaranteed: 260°C/10 seconds

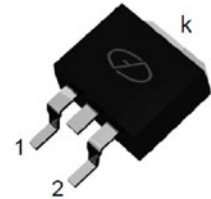

Package: TO-263

Mechanical Data

- Case: JEDEC TO-263, molded plastic body
- Terminals: Solderable per MIL-STD-202,method 208
- Polarity: As marked
- Mounting Position: Any

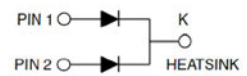

Schematic Diagram

Maximum Ratings & Electrical Characteristics

(Ratings at 25°C ambient temperature unless otherwise specified, single phase, half wave, resistive or inductive load. For capacitive load, derate by 20%.)

Parameter	Symbol	Value	Unit
Maximum Repetitive Peak Reverse Voltage	V_{RRM}	60	V
Maximum RMS Voltage	V_{RMS}	42	V
Maximum DC Blocking Voltage	V_{DC}	60	V
Maximum Average Forward Rectified Current (see Fig.1)	Per Leg	5	A
	Total Device	10	
Peak Forward Surge Current 8.3ms Single Half Sine-Wave Superimposed on Rated Load (JEDEC Method)	I_{FSM}	150	A
Maximum Instantaneous Forward Voltage at 5.0A Per Leg ¹	V_F	0.75	V
Maximum Instantaneous Reverse Current at Rated DC Blocking Voltage ¹	$T_J=25^{\circ}C$	100	uA
	$T_J=100^{\circ}C$	5	mA
	$T_J=125^{\circ}C$	-	mA
Typical Thermal Resistance ²	$R_{\theta JC}$	2.5	°C/W
Operating Junction Temperature Range	T_J	-55 to +150	°C
Storage Temperature Range	T_{STG}	-55 to +150	°C

Notes:

- 1.Pulse test: 300µs pulse width, 1% duty cycle.
- 2.Thermal resistance from junction to case.

Ratings and Characteristics Curves

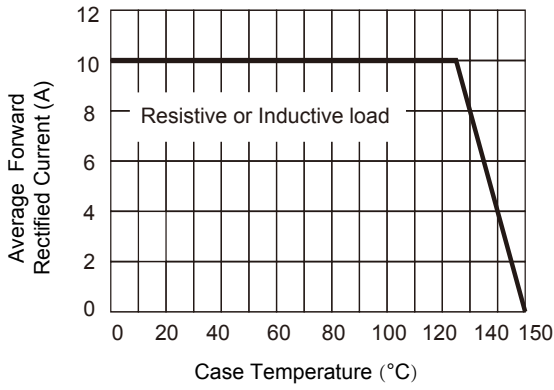

Figure 1. Forward Current Derating Curve

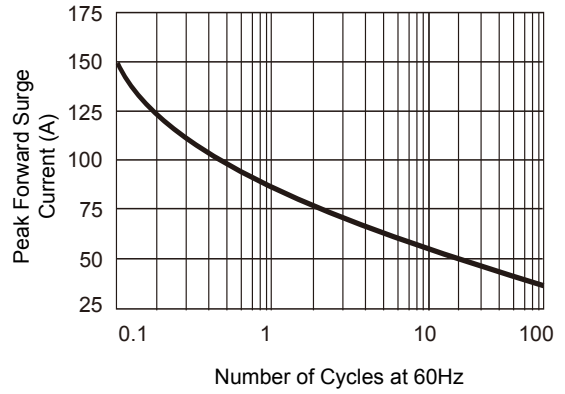

Figure 2. Maximum Non-Repetitive Peak Forward Surge Current

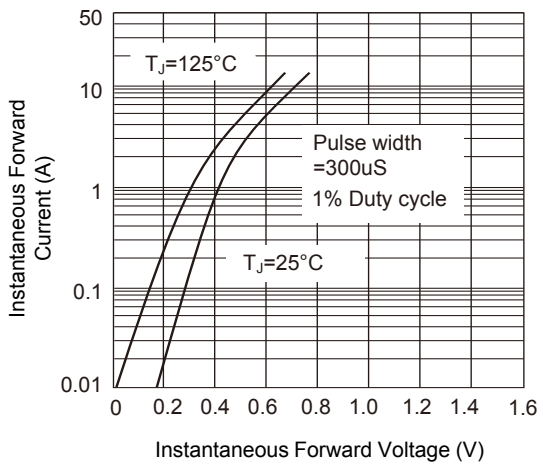

Figure 3. Typical Instantaneous Forward Characteristics

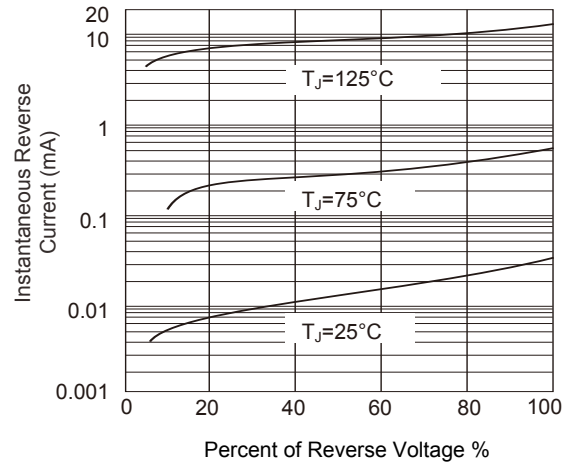
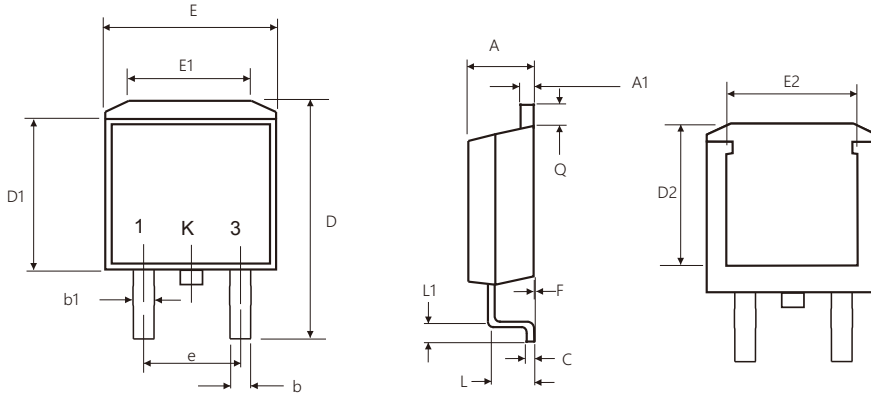

Figure 4. Typical Reverse Characteristics

Package Outline Dimensions (TO-263)



Symbol	Dimensions In Millimeters		Dimensions In Inches	
	Min.	Max.	Min.	Max.
A	4.06	4.83	0.160	0.190
A1	1.14	1.40	0.045	0.055
e	4.98	5.18	0.196	0.204
b	0.69	0.94	0.027	0.037
b1	1.20	1.34	0.047	0.053
C	0.35	0.46	0.014	0.018
D	14.22	16.22	0.560	0.639
D1	8.13	9.14	0.320	0.360
E	9.65	10.67	0.380	0.420
E1	6.22	-	0.245	-
L	2.67	3.40	0.105	0.134
L1	2.29	3.32	0.090	0.131
Q	0.92	1.68	0.036	0.066
F	0.02	0.30	0.001	0.012
D2	7.20	7.80	0.283	0.307
E2	7.60	8.20	0.299	0.323

Order Information

Device	Package	Marking	Quantity	HSF Status
GSMBRB1060CT	TO-263	MBRB1060CT	800pcs / Reel	RoHS Compliant