

Features

- Heatsink design
- Schottky barrier diodes
- Low forward voltage drop
- Low leakage current
- Moisture sensitivity: level 1, per J-STD-020
- Solder dip 260 °C, 10 s
- Low profile - typical height of 1.1 mm
- High temperature soldering guaranteed: 260°C/10 seconds
- Halogen-free according to IEC 61249-2-21 definition

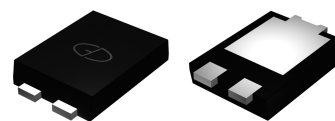

Package:
eSGC (TO-277)

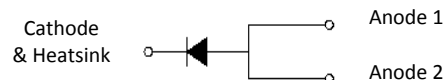

Schematic Diagram

Applications

For low voltage high frequency inverters, DC/DC converters and polarity protection applications.

Maximum Ratings (T_A = 25°C unless otherwise noted)

Parameter	Symbol	Value	Unit
Peak Repetitive Peak Reverse Voltage	V _{RRM}	120	V
Maximum RMS Voltage	V _{RMS}	84	V
DC Blocking Voltage	V _{DC}	120	V
Maximum Average Forward Rectified Current	I _{F(AV)}	10.0 ¹⁾ 20.0 ²⁾	A
Peak Forward Surge Current 8.3 ms Single Half Sine-Wave Superimposed on Rated Load	I _{FSM}	250	A
Operating Junction and Storage Temperature Range	T _J , T _{STG}	-55 to +150	°C

Electrical Characteristics (T_A=25°C unless otherwise noted)

Parameter	Test Conditions	Symbol	TYP.	MAX.	Unit	
Maximum Instantaneous Forward Voltage	I _F =1A I _F =2A I _F =5A I _F =20A	T _A =25°C	V _F	0.37	0.42	V
				0.407	0.45	
				0.48	0.55	
				0.74	0.79	
	I _F =1A I _F =2A I _F =5A I _F =20A	T _A =125°C	0.25	-		
			0.30	-		
			0.42	-		
			0.60	-		
Maximum DC Reverse Current at Rated DC Blocking Voltage	Rated VR	T _A =25°C	0.019	0.2	mA	
		T _A =125°C	16.8	30		
Typical Junction Capacitance	4.0 V, 1 MHz	C _J	1576		pF	
Typical Thermal Resistance	Junction to Lead	R _{θJL} ²⁾	3		°C/W	
	Junction to Ambient	R _{θJA} ¹⁾	27			

Notes:

- 1) Mounted on FR-4 P.C.B with 30*30mm copper pad area
- 2) On aluminum substrate PCB with recommended copper pad area

Typical Characteristics Curves

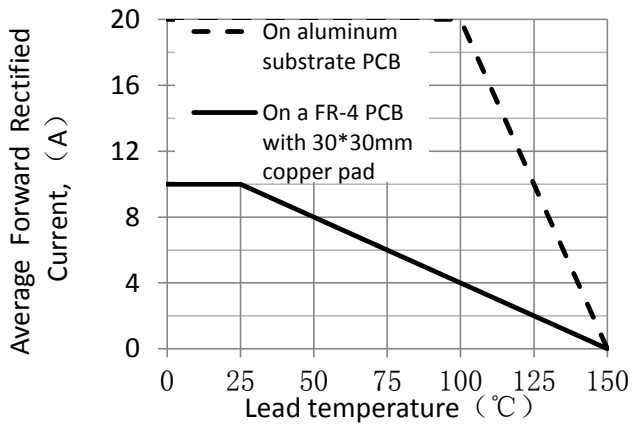

Figure 1. Forward Current Derating Curve

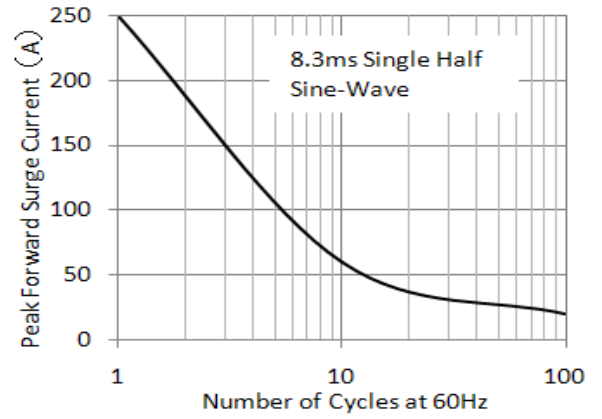

Figure 2. Maximum Non-Repetitive Peak Forward Surge Current

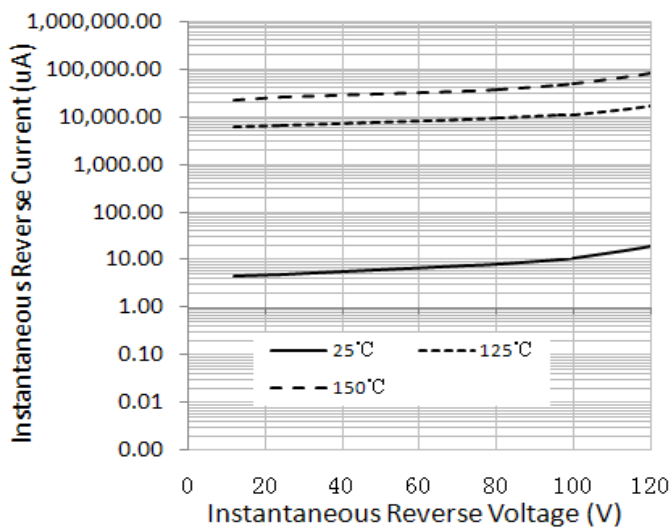

Figure 3. Typical Reverse Characteristics

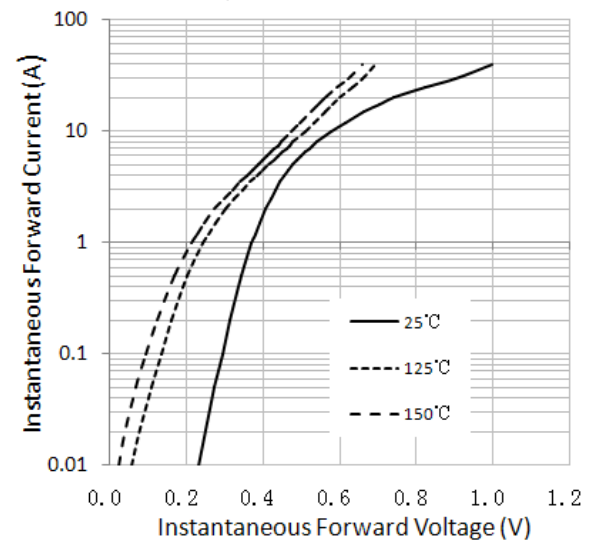

Figure 4. Typical Instantaneous Forward Characteristics

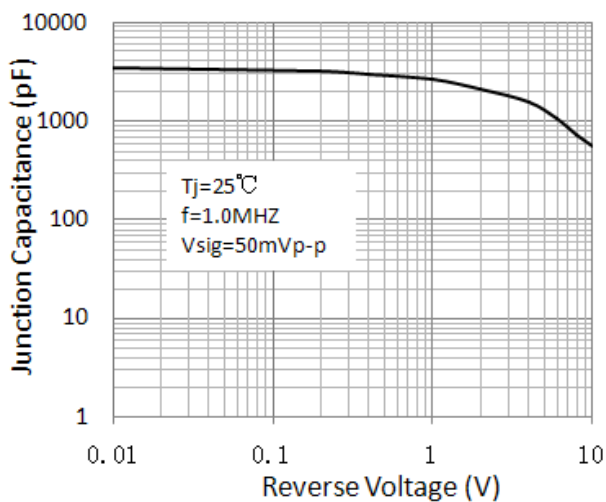
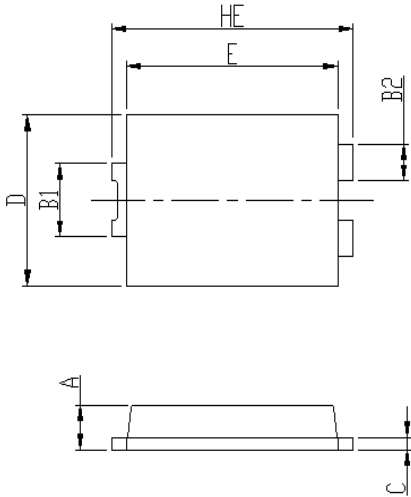
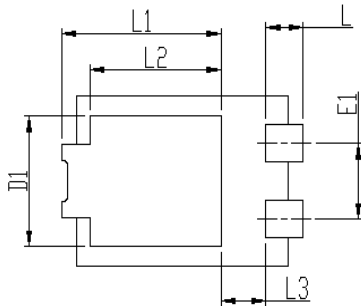

Figure 5. Typical Junction Capacitance

Package Outline Dimensions eSGC (TO-277)



DIM	Unit: mm		Unit: inch	
	MIN	MAX	MIN	MAX
HE	6.4	6.6	0.252	0.260
E	5.6	5.8	0.220	0.228
D	4.1	4.3	0.161	0.169
B1	1.7	1.9	0.067	0.075
B2	0.8	1	0.031	0.039
A	1.05	1.2	0.041	0.047
C	0.3	0.4	0.012	0.016
L	0.85	1.1	0.033	0.043
L1	4.2	4.4	0.165	0.173
L2	3.52 Typ.		0.139 Typ.	
L3	1.1	1.4	0.043	0.055
D1	3	3.3	0.118	0.130
E1	1.86 Typ.		0.073 Typ.	



Soldering footprint

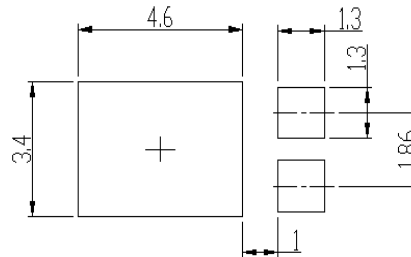

Suggested Pad Layout

