

Features

- Small outline surface mount package
- Low current leakage
- For high-speed switching applications

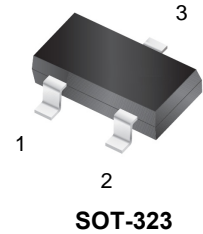

Applications

- High speed switching
- Circuit protecting
- Voltage clamping

Schematic Diagram

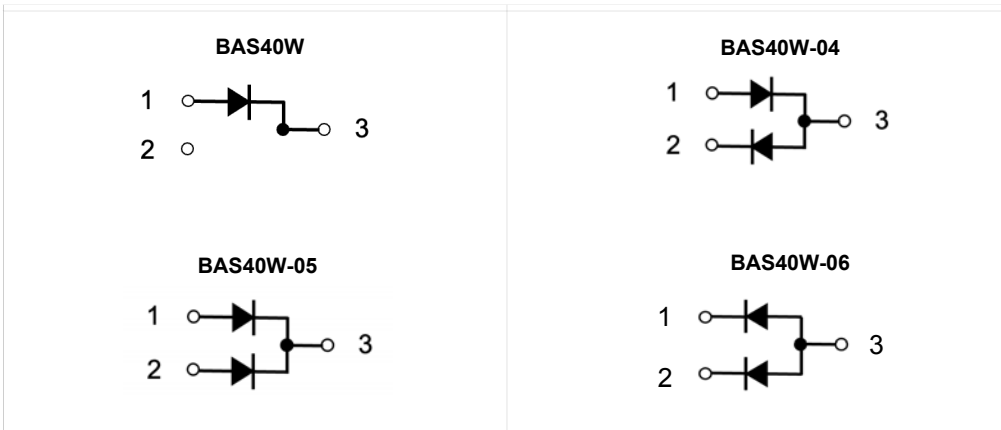

Absolute Maximum Ratings (T_A=25°C unless otherwise noted)

Parameter	Symbol	Value	Unit
Peak Repetitive Reverse Voltage	V _R RM	40	V
Working Peak Reverse Voltage	V _R WM		
DC Blocking Voltage	V _R		
Forward Continuous Current	I _{FM}	200	mA
Power Dissipation	P _D	200	mW
Thermal Resistance, Junction-to-Ambient	R _θ JA	500	°C/W
Operating Junction Temperature Range	T _J	-55 To +125	°C
Storage Temperature Range	T _{STG}	-55 To +150	°C

Electrical Characteristics ($T_A=25^\circ\text{C}$ unless otherwise noted)

Parameter	Symbol	Conditions	Min.	Max.	Unit
Reverse Breakdown Voltage	$V_{(BR)}$	$I_R=10\mu\text{A}$	40	-	V
Forward Voltage	V_F	$I_F=1\text{mA}$	-	380	mV
		$I_F=40\text{mA}$	-	1000	mV
Reverse Leakage Current	I_R	$V_R=30\text{V}$	-	200	nA
Diode Capacitance	C_D	$V_R=0\text{V}$, $f=1\text{MHz}$	-	5	pF
Reverse Recovery Time	t_{rr}	$I_F=I_R=10\text{mA}$, $I_{rr}=1\text{mA}$ $R_L=100\Omega$	-	5	ns

Typical Characteristic Curves

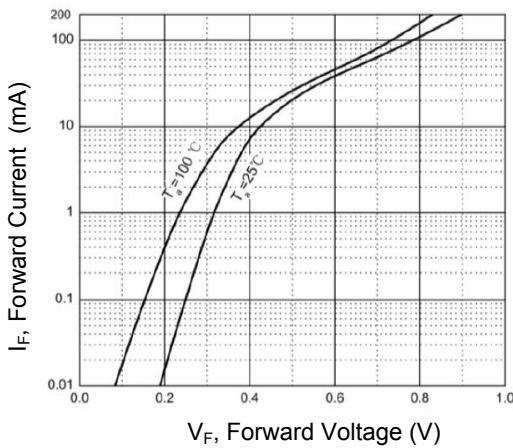

Figure 1. Forward Characteristics

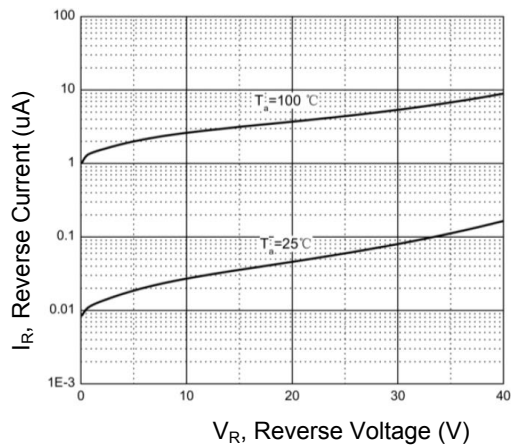

Figure 2. Reverse Characteristics

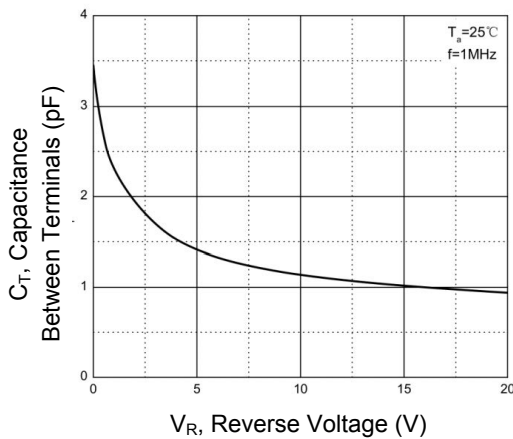

Figure 3. Capacitance Characteristics

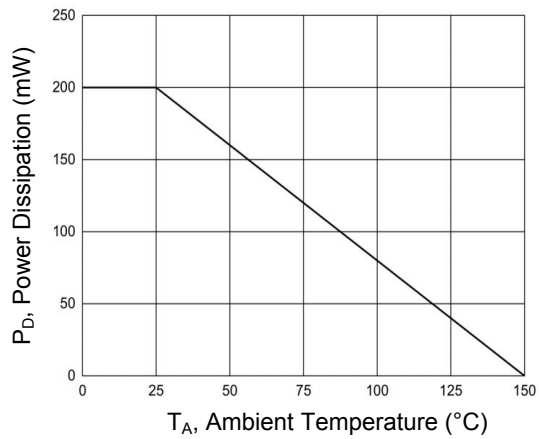
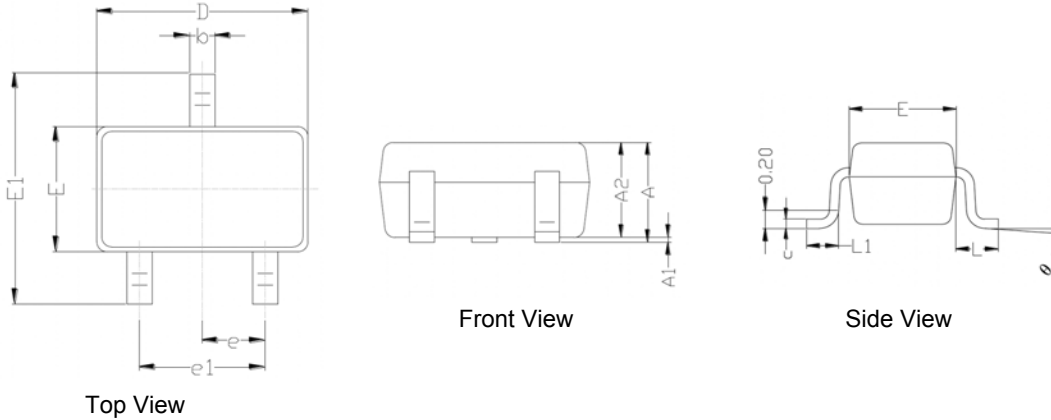

Figure 4. Power Derating Curve

Package Outline Dimensions (SOT-323)



Symbol	Dimensions in Millimeters		Dimensions in Inches	
	Min	Max	Min	Max
A	0.900	1.100	0.035	0.043
A1	0.000	0.100	0.000	0.004
A2	0.900	1.000	0.035	0.039
b	0.200	0.400	0.008	0.016
c	0.080	0.150	0.003	0.006
D	2.000	2.200	0.079	0.087
E	1.150	1.350	0.045	0.053
E1	2.150	2.450	0.085	0.096
e	0.650 Typ.		0.026 Typ.	
e1	1.200	1.400	0.047	0.055
L	0.525 Typ.		0.021 Ref.	
L1	0.260	0.460	0.010	0.018
theta	0°	8°	0°	8°

Recommended Pad Layout

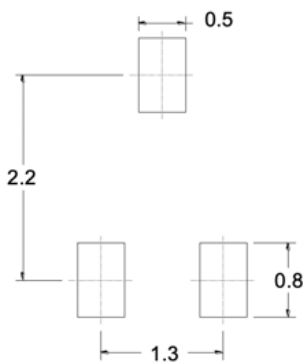

Notes:

1. Dimensions in millimeters
2. The pad layout is for reference

Order Information

Device	Package	Marking	Carrier	Quantity
BAS40W	SOT-323	43	Tape & Reel	3,000pcs / Reel
BAS40W-04	SOT-323	44	Tape & Reel	3,000pcs / Reel
BAS40W-05	SOT-323	45	Tape & Reel	3,000pcs / Reel
BAS40W-06	SOT-323	46	Tape & Reel	3,000pcs / Reel