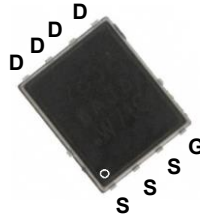
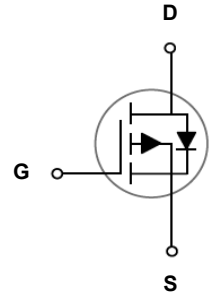


### Main Product Characteristics

$V_{(BR)DSS}$	-40V
$R_{DS(ON)}$	5.8mΩ
$I_D$	-85A



PPAK5X6



Schematic Diagram

### Features and Benefits

- Advanced MOSFET process technology
- Ideal for high efficiency switched mode power supplies
- Low on-resistance with low gate charge
- Fast switching and reverse body recovery



### Description

The SSFP4959 utilizes the latest techniques to achieve high cell density and low on-resistance. These features make this device extremely efficient and reliable for use in high efficiency switch mode power supply and a wide variety of other applications.

### Absolute Maximum Ratings ( $T_C=25^{\circ}C$ unless otherwise specified)

Parameter	Symbol	Rating	Unit
Drain-Source Voltage	$V_{DS}$	-40	V
Gate-Source Voltage	$V_{GS}$	$\pm 20$	V
Drain Current – Continuous ( $T_C=25^{\circ}C$ )	$I_D$	-85	A
Drain Current – Continuous ( $T_C=100^{\circ}C$ )		-53.7	A
Drain Current – Pulsed <sup>1</sup>	$I_{DM}$	-340	A
Single Pulse Avalanche Energy <sup>2</sup>	$E_{AS}$	245	mJ
Single Pulse Avalanche Current <sup>2</sup>	$I_{AS}$	-70	A
Power Dissipation ( $T_C=25^{\circ}C$ )	$P_D$	135	W
Power Dissipation – Derate above 25°C		1.09	W/°C
Storage Temperature Range	$T_{STG}$	-50 to +150	°C
Operating Junction Temperature Range	$T_J$	-50 to +150	°C

### Thermal Characteristics

Parameter	Symbol	Typ.	Max.	Unit
Thermal Resistance Junction to Ambient	$R_{\theta JA}$	---	62	°C /W
Thermal Resistance Junction to Case	$R_{\theta JC}$	---	0.92	°C /W

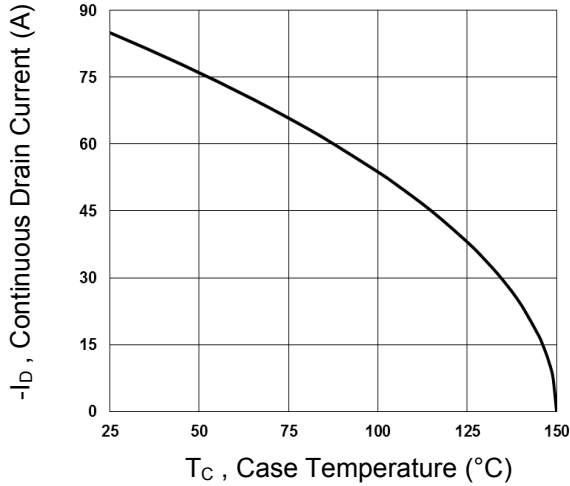
**Electrical Characteristics** ( $T_J=25^\circ\text{C}$  unless otherwise specified)

Parameter	Symbol	Conditions	Min.	Typ.	Max.	Unit
<b>Off Characteristics</b>						
Drain-Source Breakdown Voltage	$BV_{DSS}$	$V_{GS}=0V, I_D=-250\mu A$	-40	---	---	V
$BV_{DSS}$ Temperature Coefficient	$\Delta BV_{DSS}/\Delta T_J$	Reference to $25^\circ\text{C}$ , $I_D=-1\text{mA}$	---	-0.03	---	$V/^\circ\text{C}$
Drain-Source Leakage Current	$I_{DSS}$	$V_{DS}=-40V, V_{GS}=0V, T_J=25^\circ\text{C}$	---	---	-1	$\mu\text{A}$
		$V_{DS}=-32V, V_{GS}=0V, T_J=125^\circ\text{C}$	---	---	-10	$\mu\text{A}$
Gate-Source Leakage Current	$I_{GSS}$	$V_{GS}=\pm 20V, V_{DS}=0V$	---	---	$\pm 100$	nA
<b>On Characteristics</b>						
Static Drain-Source On-Resistance	$R_{DS(ON)}$	$V_{GS}=-10V, I_D=-25A$	---	4.7	5.8	$\text{m}\Omega$
		$V_{GS}=-4.5V, I_D=-12A$	---	6.4	8.5	$\text{m}\Omega$
Gate Threshold Voltage	$V_{GS(th)}$	$V_{GS}=V_{DS}, I_D=-250\mu A$	-1.2	-1.6	-2.5	V
$V_{GS(th)}$ Temperature Coefficient	$\Delta V_{GS(th)}$		---	5.38	---	$\text{mV}/^\circ\text{C}$
Forward Transconductance	$g_{fs}$	$V_{DS}=-10V, I_D=-3A$	---	15	---	S
<b>Dynamic and switching Characteristics</b>						
Total Gate Charge <sup>3, 4</sup>	$Q_g$	$V_{DS}=-32V, V_{GS}=-10V, I_D=-10A$	---	106	160	nC
Gate-Source Charge <sup>3, 4</sup>	$Q_{gs}$		---	13.1	20	
Gate-Drain Charge <sup>3, 4</sup>	$Q_{gd}$		---	24.9	38	
Turn-On Delay Time <sup>3, 4</sup>	$T_{d(on)}$	$V_{DD}=-32V, V_{GS}=-10V, R_G=6\Omega, I_D=-1A$	---	41.6	82	nS
Rise Time <sup>3, 4</sup>	$T_r$		---	12.7	26	
Turn-Off Delay Time <sup>3, 4</sup>	$T_{d(off)}$		---	308	600	
Fall Time <sup>3, 4</sup>	$T_f$		---	70	140	
Input Capacitance	$C_{iss}$	$V_{DS}=-25V, V_{GS}=0V, F=1\text{MHz}$	---	5720	8580	pF
Output Capacitance	$C_{oss}$		---	527	790	
Reverse Transfer Capacitance	$C_{rss}$		---	352	528	
Gate Resistance	$R_g$	$V_{GS}=0V, V_{DS}=0V, F=1\text{MHz}$	---	4.2	6.3	$\Omega$
<b>Drain-Source Diode Characteristics and Maximum Ratings</b>						
Continuous Source Current	$I_S$	$V_G=V_D=0V, \text{Force Current}$	---	---	-85	A
Pulsed Source Current	$I_{SM}$		---	---	-340	A
Diode Forward Voltage	$V_{SD}$	$V_{GS}=0V, I_S=-1A, T_J=25^\circ\text{C}$	---	---	-1	V

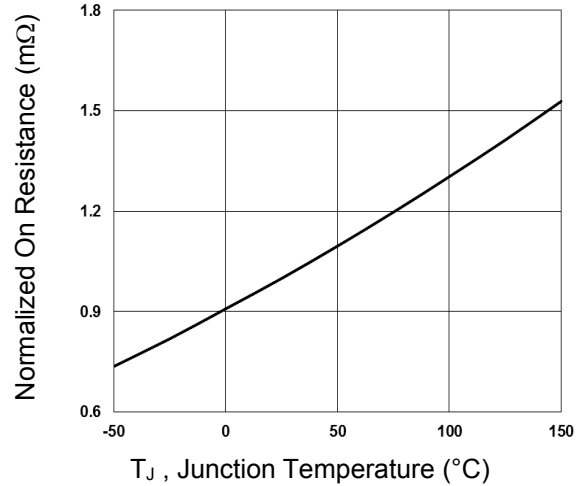
Note:

1. Repetitive Rating: Pulsed width limited by maximum junction temperature.
2.  $V_{DD}=-25V, V_{GS}=-10V, L=0.1\text{mH}, I_{AS}=-70A, R_G=25\Omega, \text{Starting } T_J=25^\circ\text{C}$
3. The data tested by pulsed, pulse width  $\leq 300\mu\text{s}$ , duty cycle  $\leq 2\%$ .
4. Essentially independent of operating temperature.

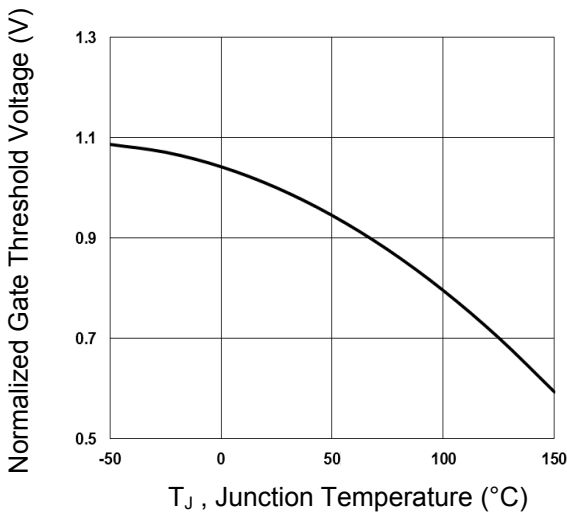
**Typical Electrical and Thermal Characteristic Curves**



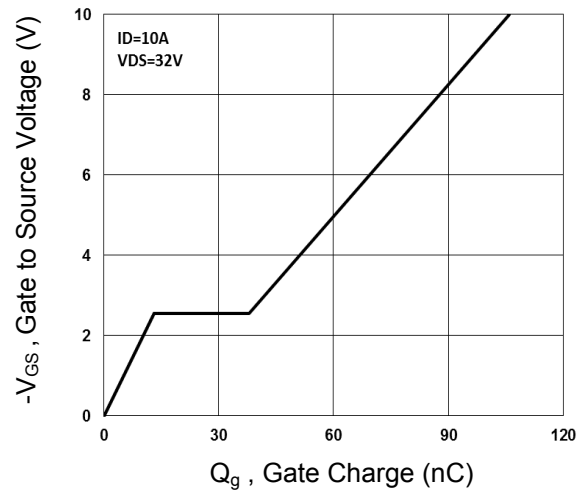
**Fig.1 Continuous Drain Current vs.  $T_C$**



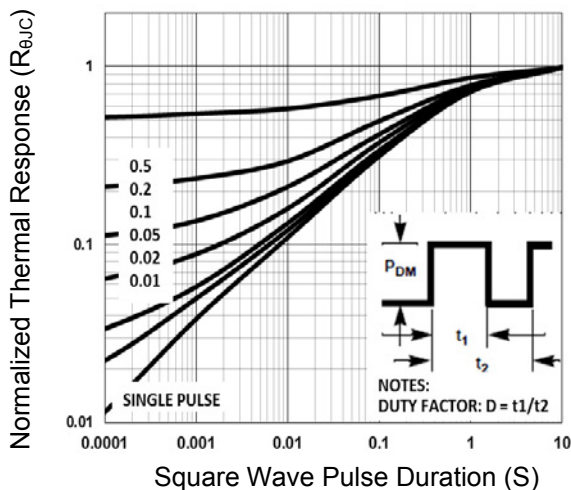
**Fig.2 Normalized  $R_{DS(ON)}$  vs.  $T_J$**



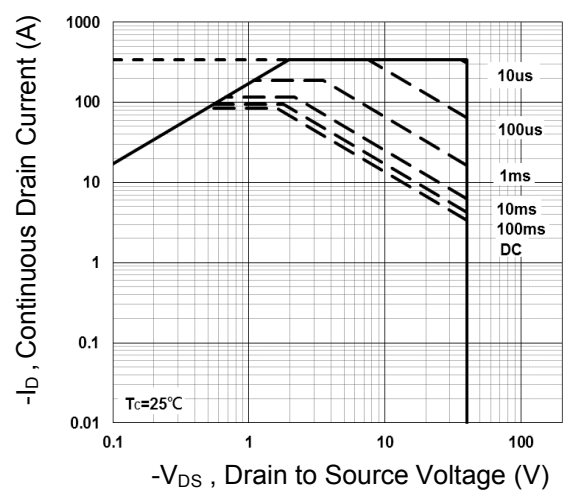
**Fig.3 Normalized  $V_{th}$  vs.  $T_J$**



**Fig.4 Gate Charge Waveform**

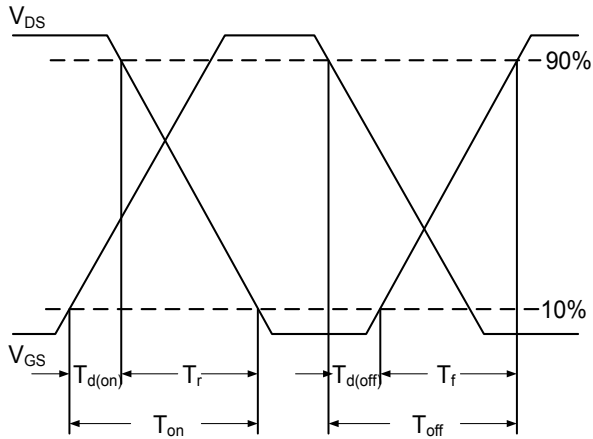


**Fig.5 Normalized Transient Impedance**

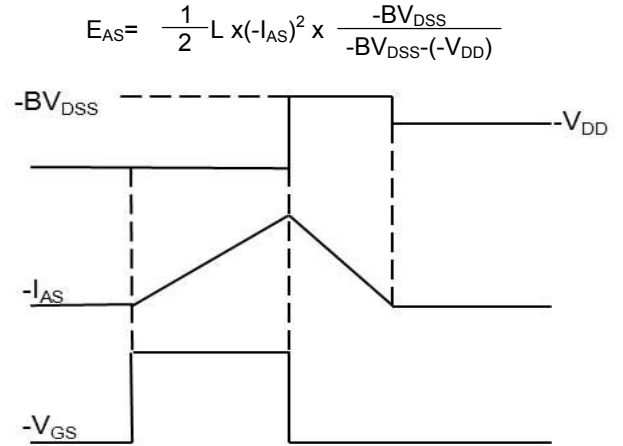


**Fig.6 Maximum Safe Operation Area**

**Typical Electrical and Thermal Characteristic Curves**



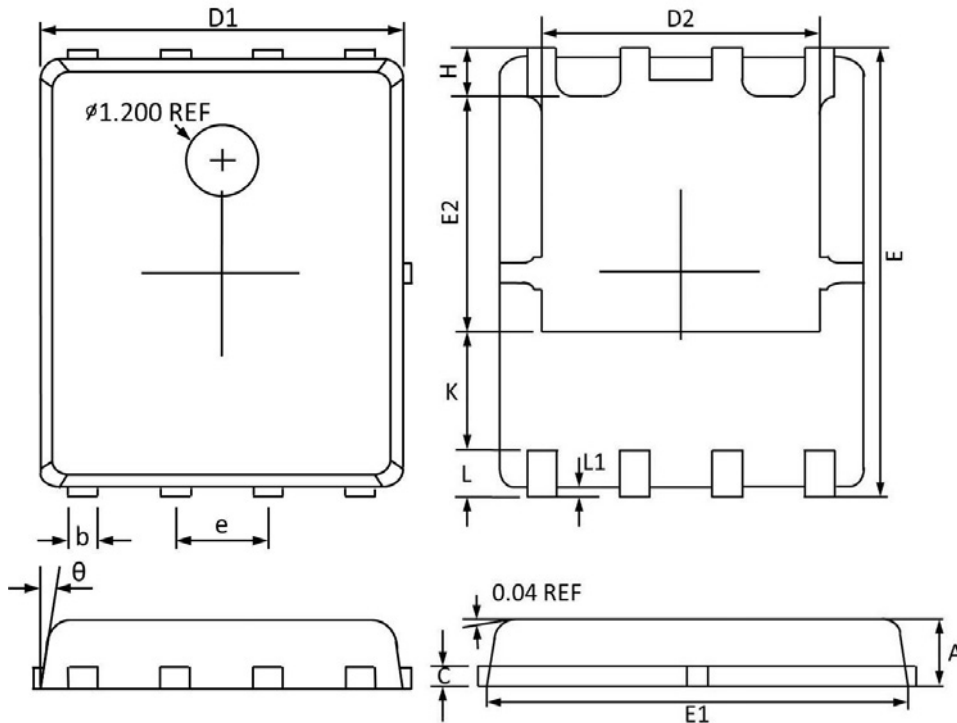
**Fig.7 Switching Time Waveform**



**Fig.8  $E_{AS}$  Waveform**

**Package Outline Dimensions**

**PPAK5X6**



Symbol	Dimensions In Millimeters		Dimensions In Inches	
	MAX	MIN	MAX	MIN
A	1.100	0.800	0.043	0.031
b	0.510	0.330	0.020	0.013
C	0.300	0.200	0.012	0.008
D1	5.100	4.800	0.201	0.189
D2	4.100	3.610	0.161	0.142
E	6.200	5.900	0.244	0.232
E1	5.900	5.700	0.232	0.224
E2	3.780	3.350	0.149	0.132
e	1.27BSC		0.05BSC	
H	0.700	0.410	0.028	0.016
K	1.500	1.100	0.059	0.043
L	0.710	0.510	0.028	0.020
L1	0.200	0.060	0.008	0.002
$\theta$	12°	0°	12°	0°