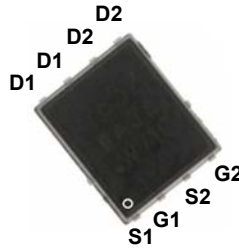
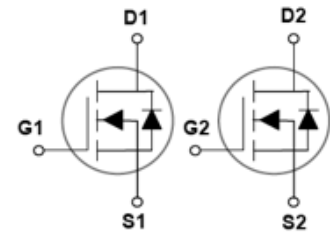


### Main Product Characteristics

$V_{(BR)DSS}$	30V
$R_{DS(ON)}$	6.5m $\Omega$
$I_D$	40A



PPAK5X6



Schematic Diagram

### Features and Benefits

- Advanced MOSFET process technology
- Ideal for high efficiency switched mode power supplies
- Low on-resistance with low gate charge
- Fast switching and reverse body recovery



### Description

The SSFP3806 utilizes the latest techniques to achieve high cell density and low on-resistance. These features make this device extremely efficient and reliable for use in high efficiency switch mode power supply and a wide variety of other applications.

### Absolute Maximum Ratings (T<sub>C</sub>=25°C unless otherwise specified)

Parameter	Symbol	Rating	Unit
Drain-Source Voltage	$V_{DS}$	30	V
Gate-Source Voltage	$V_{GS}$	$\pm 20$	V
Drain Current – Continuous (T <sub>C</sub> =25°C)	$I_D$	40	A
Drain Current – Continuous (T <sub>C</sub> =100°C)		25.3	A
Drain Current – Pulsed <sup>1</sup>	$I_{DM}$	160	A
Single Pulse Avalanche Energy <sup>2</sup>	$E_{AS}$	88	mJ
Single Pulse Avalanche Current <sup>2</sup>	$I_{AS}$	42	A
Power Dissipation (T <sub>C</sub> =25°C)	$P_D$	46	W
Power Dissipation – Derate above 25°C		0.37	W/°C
Storage Temperature Range	$T_{STG}$	-55 to +150	°C
Operating Junction Temperature Range	$T_J$	-55 to +150	°C

### Thermal Characteristics

Parameter	Symbol	Typ.	Max.	Unit
Thermal Resistance Junction to Ambient	$R_{\theta JA}$	---	62	°C/W
Thermal Resistance Junction to Case	$R_{\theta JC}$	---	2.7	°C/W

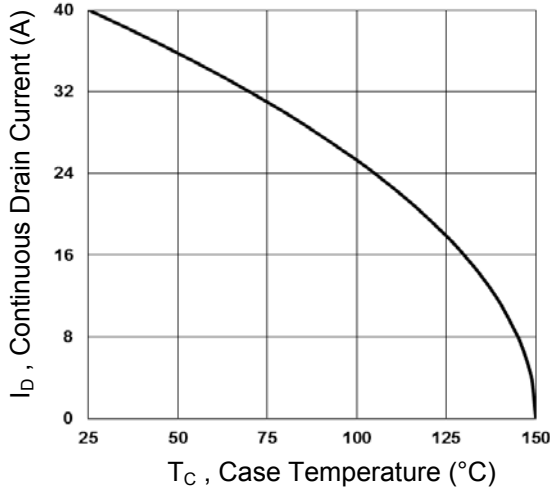
**Electrical Characteristics** ( $T_J=25^{\circ}\text{C}$  unless otherwise specified)

Parameter	Symbol	Conditions	Min.	Typ.	Max.	Unit
<b>Static State Characteristics</b>						
Drain-Source Breakdown Voltage	$BV_{DSS}$	$V_{GS}=0V, I_D=250\mu A$	30	---	---	V
$BV_{DSS}$ Temperature Coefficient	$\Delta BV_{DSS}/\Delta T_J$	Reference to $25^{\circ}\text{C}$ , $I_D=1\text{mA}$	---	0.04	---	$V/^{\circ}\text{C}$
Drain-Source Leakage Current	$I_{DSS}$	$V_{DS}=30V, V_{GS}=0V, T_J=25^{\circ}\text{C}$	---	---	1	$\mu A$
		$V_{DS}=24V, V_{GS}=0V, T_J=125^{\circ}\text{C}$	---	---	10	$\mu A$
Gate-Source Leakage Current	$I_{GSS}$	$V_{GS}=\pm 20V, V_{DS}=0V$	---	---	$\pm 100$	nA
Static Drain-Source On-Resistance <sup>3</sup>	$R_{DS(ON)}$	$V_{GS}=10V, I_D=20A$	---	5.5	6.5	$m\Omega$
		$V_{GS}=4.5V, I_D=10A$	---	7	9	$m\Omega$
Gate Threshold Voltage	$V_{GS(th)}$	$V_{GS}=V_{DS}, I_D=250\mu A$	1	1.6	2.5	V
$V_{GS(th)}$ Temperature Coefficient	$\Delta V_{GS(th)}$		---	-4	---	$mV/^{\circ}\text{C}$
Forward Transconductance	$g_{fs}$	$V_{DS}=10V, I_D=10A$	---	18	---	S
<b>Dynamic Characteristics</b>						
Total Gate Charge <sup>3, 4</sup>	$Q_g$	$V_{DS}=15V, V_{GS}=4.5V, I_D=20A$	---	11.1	22	nC
Gate-Source Charge <sup>3, 4</sup>	$Q_{gs}$		---	1.85	4	
Gate-Drain Charge <sup>3, 4</sup>	$Q_{gd}$		---	6.8	13	
Turn-On Delay Time <sup>3, 4</sup>	$T_{d(on)}$	$V_{DD}=15V, V_{GS}=10V, R_G=3.3\Omega, I_D=15A$	---	7.5	15	nS
Rise Time <sup>3, 4</sup>	$T_r$		---	14.5	28	
Turn-Off Delay Time <sup>3, 4</sup>	$T_{d(off)}$		---	35.2	70	
Fall Time <sup>3, 4</sup>	$T_f$		---	9.6	20	
Input Capacitance	$C_{iss}$	$V_{DS}=25V, V_{GS}=0V, F=1\text{MHz}$	---	1160	1750	pF
Output Capacitance	$C_{oss}$		---	200	300	
Reverse Transfer Capacitance	$C_{rss}$		---	180	270	
Gate Resistance	$R_g$	$V_{GS}=0V, V_{DS}=0V, F=1\text{MHz}$	---	2.5	5	$\Omega$
<b>Guaranteed Avalanche Energy</b>						
Single Pulse Avalanche Energy	EAS	$V_{DD}=25V, L=0.1\text{mH}, I_{AS}=20A$	20	---	---	mJ
<b>Drain-Source Diode Characteristics</b>						
Continuous Source Current	$I_S$	$V_G=V_D=0V$ , Force Current	---	---	40	A
Pulsed Source Current <sup>3</sup>	$I_{SM}$		---	---	80	A
Diode Forward Voltage <sup>3</sup>	$V_{SD}$	$V_{GS}=0V, I_S=1A, T_J=25^{\circ}\text{C}$	---	---	1	V

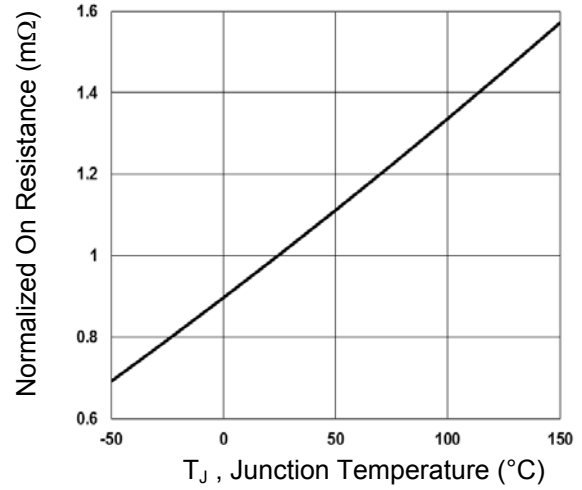
Note:

1. Repetitive Rating: Pulsed width limited by maximum junction temperature.
2.  $V_{DD}=25V, V_{GS}=10V, L=0.1\text{mH}, I_{AS}=42A, R_G=25\Omega$ , Starting  $T_J=25^{\circ}\text{C}$ .
3. The data tested by pulsed, pulse width  $\leq 300\mu\text{s}$ , duty cycle  $\leq 2\%$ .
4. Essentially independent of operating temperature.

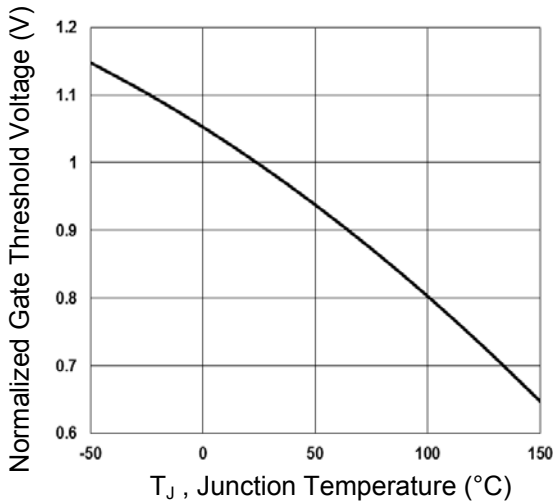
**Typical Electrical and Thermal Characteristic Curves**



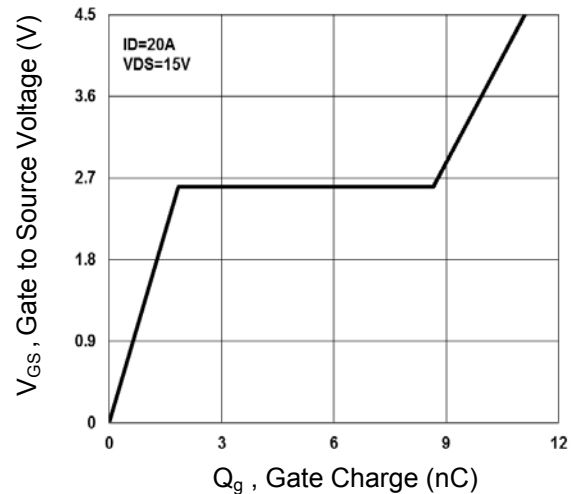
**Fig.1 Continuous Drain Current vs.  $T_c$**



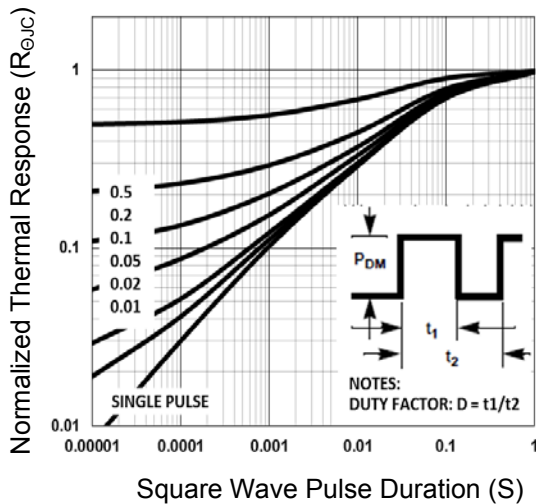
**Fig.2 Normalized  $R_{DS(ON)}$  vs.  $T_j$**



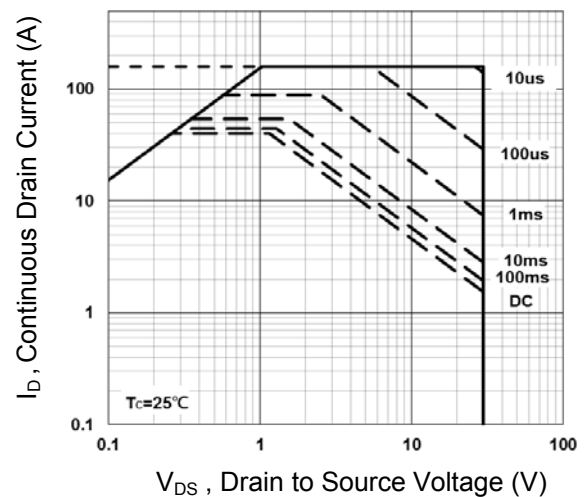
**Fig.3 Normalized  $V_{th}$  vs.  $T_j$**



**Fig.4 Gate Charge Waveform**

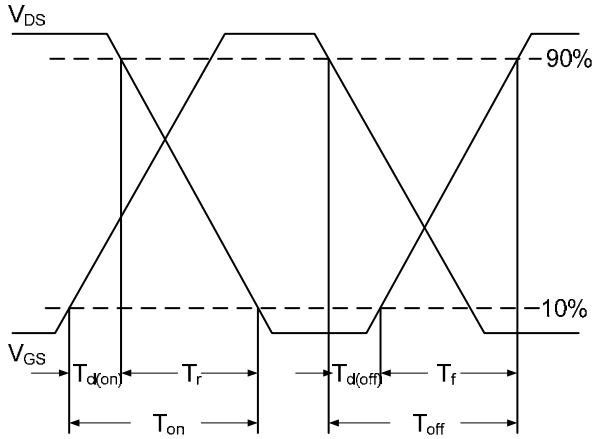


**Fig.5 Normalized Transient Impedance**

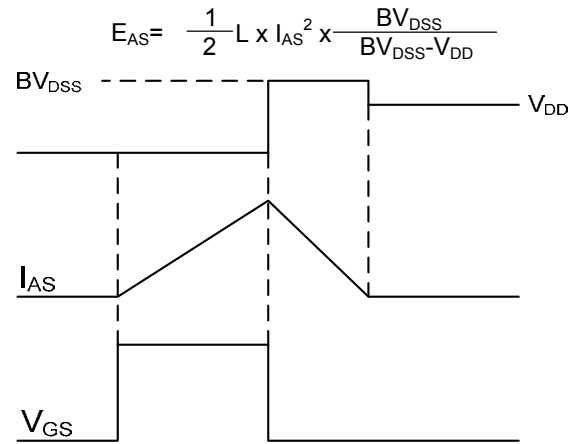


**Fig.6 Maximum Safe Operation Area**

**Typical Electrical and Thermal Characteristic Curves**



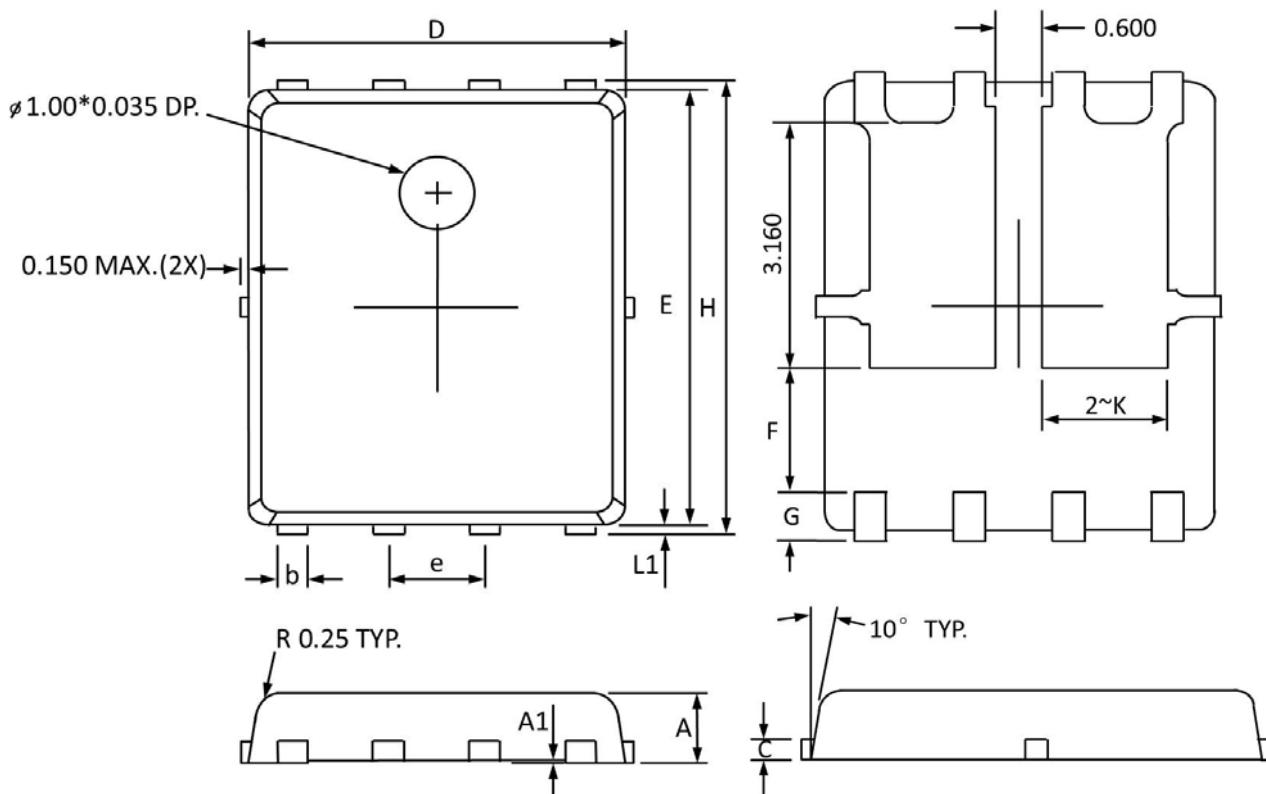
**Fig.7 Switching Time Waveform**



**Fig.8  $E_{AS}$  Waveform**

## Package Outline Dimensions

## PPAK5X6



Symbol	Dimensions In Millimeters		Dimensions In Inches	
	Min	Max	Min	Max
A	0.800	1.000	0.032	0.039
A1	0.000	0.005	0.000	0.000
b	0.350	0.490	0.014	0.019
C	0.254 Ref		0.254 Ref	
D	4.900	5.100	0.193	0.200
E	5.700	5.900	0.225	0.232
e	1.27 BSC		1.27 BSC	
F	1.600 Ref		1.600 Ref	
G	0.600 Ref		0.600 Ref	
H	5.950	6.200	0.235	0.244
L1	0.100	0.180	0.004	0.007
K	1.600 Ref		1.600 Ref	