

Main Product Characteristics

BV_{DSS}	40V
$R_{DS(ON)}$	2.5m Ω
I_D	180A

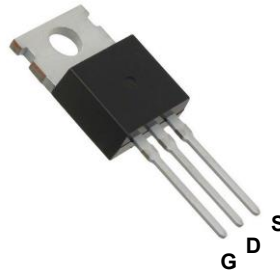

TO-220

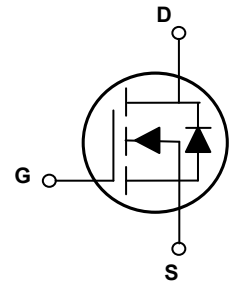

Schematic Diagram

Features and Benefits

- Advanced MOSFET process technology
- Ideal for high efficiency switched mode power supplies
- Low on-resistance with low gate charge
- Fast switching and reverse body recovery



Description

The GSFH74180 utilizes the latest techniques to achieve high cell density and low on-resistance. These features make this device extremely efficient and reliable for use in high efficiency switch mode power supply and a wide variety of other applications.

Absolute Maximum Ratings ($T_C=25^{\circ}C$ unless otherwise specified)

Parameter	Symbol	Max.	Unit
Drain-Source Voltage	V_{DS}	40	V
Gate-Source Voltage	V_{GS}	+20/-12	V
Drain Current-Continuous ($T_C=25^{\circ}C$)	I_D	180	A
Drain Current-Continuous ($T_C=100^{\circ}C$)		114	
Drain Current-Pulsed ¹	I_{DM}	720	A
Single Pulse Avalanche Energy ²	E_{AS}	320	mJ
Single Pulse Avalanche Current ²	I_{AS}	80	A
Power Dissipation ($T_C=25^{\circ}C$)	P_D	160	W
Power Dissipation-De-rate above 25 $^{\circ}C$		1.28	
Thermal Resistance, Junction-to-Ambient	$R_{\theta JA}$	62	$^{\circ}C/W$
Thermal Resistance, Junction-to-Case	$R_{\theta JC}$	0.78	$^{\circ}C/W$
Operating Junction Temperature Range	T_J	-50 To +150	$^{\circ}C$
Storage Temperature Range	T_{STG}	-50 To +150	$^{\circ}C$

Electrical Characteristics ($T_J=25^{\circ}\text{C}$ unless otherwise specified)

Parameter	Symbol	Conditions	Min.	Typ.	Max.	Unit
On/Off Characteristics						
Drain-Source Breakdown Voltage	BV_{DSS}	$V_{GS}=0V, I_D=250\mu A$	40	-	-	V
Drain-Source Leakage Current	I_{DSS}	$V_{DS}=40V, V_{GS}=0V, T_J=25^{\circ}\text{C}$	-	-	1	μA
		$V_{DS}=32V, V_{GS}=0V, T_J=85^{\circ}\text{C}$	-	-	10	μA
Gate-Source Leakage Current	I_{GSS}	$V_{GS}=20V, V_{DS}=0V$	-	-	100	nA
Static Drain-Source On-Resistance	$R_{DS(ON)}$	$V_{GS}=10V, I_D=20A$	-	2.1	2.5	m Ω
Gate Threshold Voltage	$V_{GS(th)}$	$V_{GS}=V_{DS}, I_D=250\mu A$	2	2.8	4	V
Forward Transconductance	g_{fs}	$V_{DS}=10V, I_D=20A$	-	35	-	S
Dynamic and Switching Characteristics						
Total Gate Charge ^{3,4}	Q_g	$V_{DS}=20V, I_D=70A$ $V_{GS}=10V$	-	58.4	88	nC
Gate-Source Charge ^{3,4}	Q_{gs}		-	14.3	21.5	
Gate-Drain Charge ^{3,4}	Q_{gd}		-	12	20	
Turn-On Delay Time ^{3,4}	$t_{d(on)}$	$V_{DD}=20V, R_G=6\Omega$ $V_{GS}=10V, I_D=1A$	-	14.6	30	nS
Rise Time ^{3,4}	t_r		-	21.5	42	
Turn-Off Delay Time ^{3,4}	$t_{d(off)}$		-	52	108	
Fall Time ^{3,4}	t_f		-	83.5	167	
Input Capacitance	C_{iss}		$V_{DS}=20V, V_{GS}=0V,$ $F=1\text{MHz}$	-	3310	
Output Capacitance	C_{oss}	-		1090	1650	
Reverse Transfer Capacitance	C_{rss}	-		100	150	
Drain-Source Diode Characteristics and Maximum Ratings						
Continuous Source Current	I_S	$V_G=V_D=0V,$ Force Current	-	-	180	A
Pulsed Source Current	I_{SM}		-	-	360	A
Diode Forward Voltage	V_{SD}	$V_{GS}=0V, I_S=1A,$ $T_J=25^{\circ}\text{C}$	-	-	1	V
Reverse Recovery Time	t_{rr}	$V_R=30V, I_S=10A$ $di/dt=100A/\mu s$ $T_J=25^{\circ}\text{C}$	-	38	-	nS
Reverse Recovery Charge	Q_{rr}		-	90	-	nC

Note:

1. Repetitive rating: Pulsed width limited by maximum junction temperature.
2. $V_{DD}=25V, V_{GS}=10V, L=0.1\text{mH}, I_{AS}=80A, R_G=25\Omega$ starting $T_J=25^{\circ}\text{C}$.
3. Pulse test: pulse width $\leq 300\mu s$, duty cycle $\leq 2\%$.
4. Essentially independent of operating temperature.

Typical Electrical and Thermal Characteristic Curves

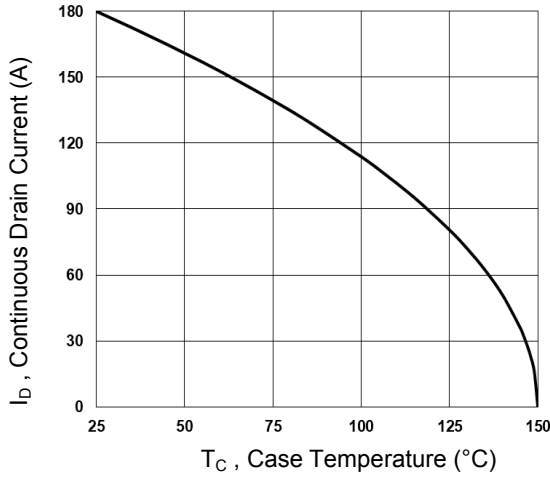

Figure 1. Continuous Drain Current vs. T_C

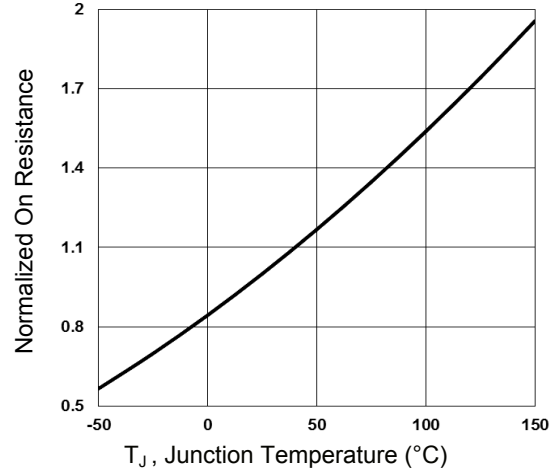

Figure 2. Normalized R_{DSON} vs. T_J

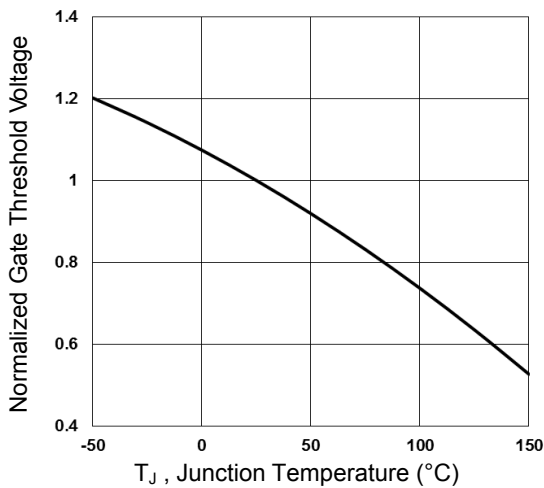

Figure 3. Normalized V_{th} vs. T_J

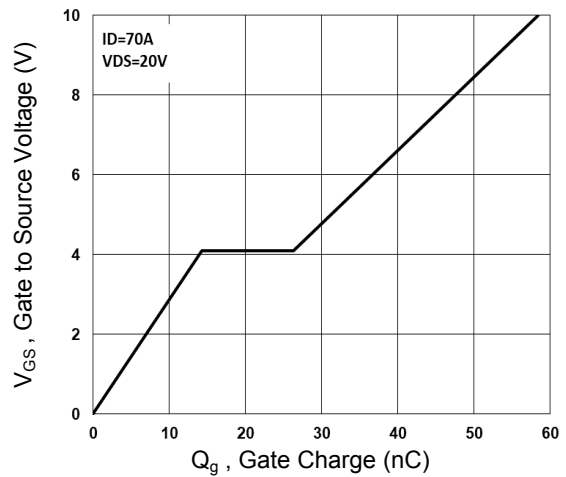

Figure 4. Gate Charge Characteristics

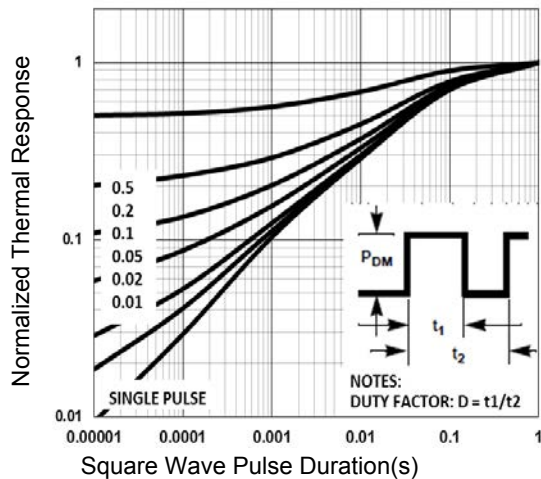

Figure 5. Normalized Transient Impedance

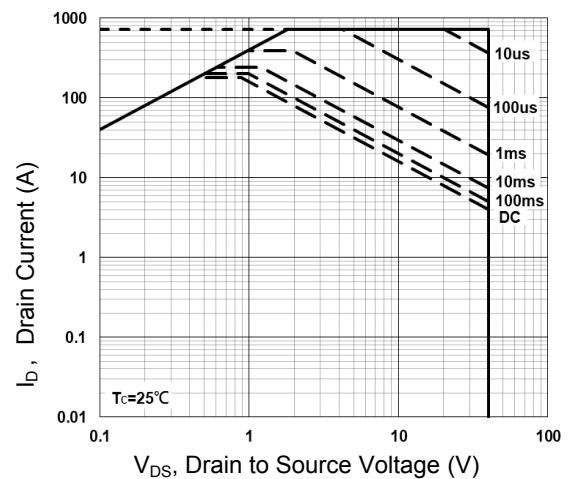

Figure 6. Maximum Safe Operation Area

Typical Electrical and Thermal Characteristic Curves

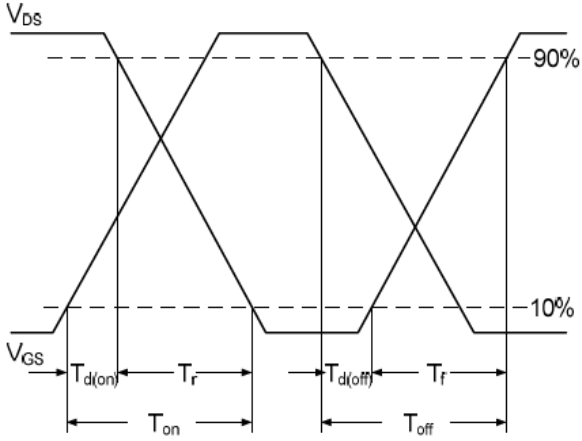

Figure 7. Switching Time Waveform

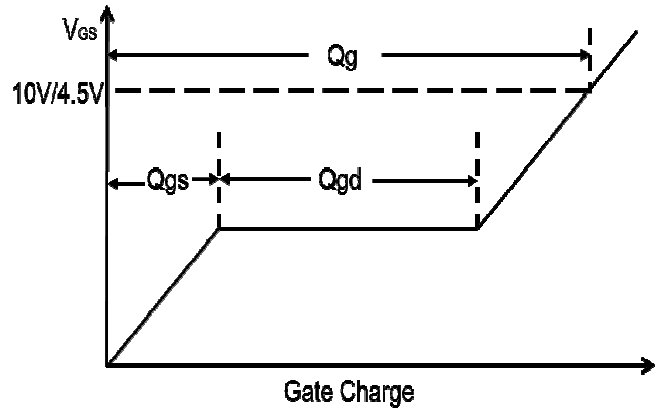
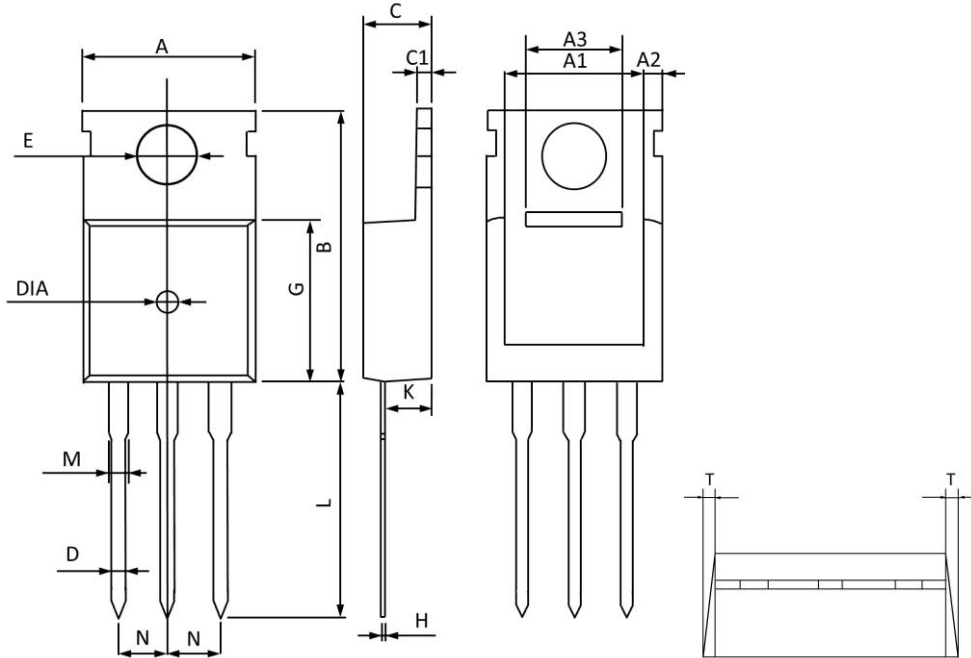

Figure 8. Gate Charge Waveform

Package Outline Dimensions TO-220



Symbol	Dimensions In Millimeters		Dimensions In Inches	
	MAX	MIN	MAX	MIN
A	10.300	9.700	0.406	0.382
A1	8.840	8.440	0.348	0.332
A2	1.250	1.050	0.049	0.041
A3	5.300	5.100	0.209	0.201
B	16.200	15.400	0.638	0.606
C	4.680	4.280	0.184	0.169
C1	1.500	1.100	0.059	0.043
D	1.000	0.600	0.039	0.024
E	3.800	3.400	0.150	0.134
G	9.300	8.700	0.366	0.343
H	0.600	0.400	0.024	0.016
K	2.700	2.100	0.106	0.083
L	13.600	12.800	0.535	0.504
M	1.500	1.100	0.059	0.043
N	2.590	2.490	0.102	0.098
T	W0.35		W0.014	
DIA	Φ1.5 TYP.	deep0.2 TYP.	Φ0.059 TYP.	deep0.008 TYP.