

Main Product Characteristics

BV_{DSS}	80V
$R_{DS(ON)}$	6.0m Ω
I_D	140A

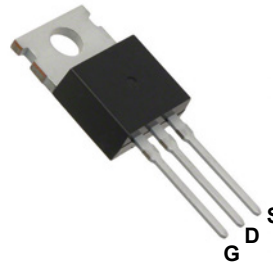

TO-220

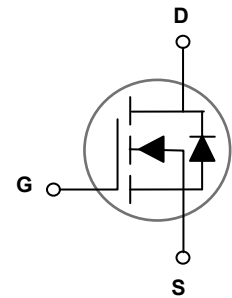

Schematic Diagram

Features and Benefits

- Advanced MOSFET process technology
- Ideal for high efficiency switched mode power supplies
- Low on-resistance with low gate charge
- Fast switching and reverse body recovery



Description

The GSFH08140 utilizes the latest techniques to achieve high cell density and low on-resistance. These features make this device extremely efficient and reliable for use in high efficiency switch mode power supply and a wide variety of other applications.

Absolute Maximum Ratings (T_C=25°C unless otherwise specified)

Parameter	Symbol	Max.	Unit
Drain-Source Voltage	V_{DS}	80	V
Gate-Source Voltage	V_{GS}	±20	V
Drain Current-Continuous(Silicon Limited)	I_D	140	A
Drain Current-Continuous(T _C =100°C)		99	A
Drain Current-Pulsed	I_{DM}	480	A
Maximum Power Dissipation	P_D	220	W
Derating Factor		1.47	W/°C
Single Pulse Avalanche Energy ⁵	E_{AS}	1200	mJ
Thermal Resistance, Junction-to-Case ²	$R_{\theta JC}$	0.68	°C/W
Storage Temperature Range	T_{STG}	-55 To +175	°C
Operating Junction Temperature Range	T_J	-55 To +175	°C

Electrical Characteristics ($T_C=25^\circ\text{C}$ unless otherwise specified)

Parameter	Symbol	Conditions	Min.	Typ.	Max.	Unit
Off Characteristics						
Drain-Source Breakdown Voltage	BV_{DSS}	$V_{GS}=0V, I_D=250\mu A$	80	-	-	V
Zero Gate Voltage Drain Current	I_{DSS}	$V_{DS}=80V, V_{GS}=0V$	-	-	1	μA
Gate-Source Leakage Current	I_{GSS}	$V_{GS}=\pm 20V, V_{DS}=0V$	-	-	± 100	nA
On Characteristics³						
Gate Threshold Voltage	$V_{GS(th)}$	$V_{DS}=V_{GS}, I_D=250\mu A$	2.0	3.0	4.0	V
Drain-Source On-State Resistance	$R_{DS(on)}$	$V_{GS}=10V, I_D=20A$	-	4.3	6.0	m Ω
Forward Transconductance	g_{FS}	$V_{DS}=5V, I_D=20A$	65	-	-	S
Dynamic Characteristics⁴						
Input Capacitance	C_{iss}	$V_{DS}=40V, V_{GS}=0V, F=1MHz$	-	7900	-	pF
Output Capacitance	C_{oss}		-	445	-	
Reverse Transfer Capacitance	C_{rss}		-	384	-	
Switching Characteristics⁴						
Turn-On Delay Time	$t_{d(on)}$	$V_{DD}=30V, R_G=2.5\Omega, V_{GS}=10V, R_L=1\Omega$	-	23	-	nS
Turn-On Rise Time	t_r		-	42	-	
Turn-Off Delay Time	$t_{d(off)}$		-	75	-	
Turn-Off Fall Time	t_f		-	26	-	
Total Gate Charge	Q_g	$V_{DS}=40V, I_D=20A, V_{GS}=10V$	-	158	-	nC
Gate-Source Charge	Q_{gs}		-	32	-	
Gate-Drain Charge	Q_{gd}		-	51	-	
Drain-Source Diode Characteristics						
Diode Forward Voltage ³	V_{SD}	$V_{GS}=0V, I_S=140A$	-	-	1.2	V
Diode Forward Current ²	I_S		-	-	140	A
Reverse Recovery Time	t_{rr}	$T_J=25^\circ\text{C}, I_F=I_S=20A, di/dt=100A/\mu s^3$	-	50	-	nS
Reverse Recovery Charge	Q_{rr}		-	110	-	nC

Notes:

1. Repetitive Rating: Pulse width limited by maximum junction temperature.
2. Surface Mounted on FR4 Board, $t \leq 10$ sec.
3. Pulse Test: Pulse Width $\leq 300\mu s$, Duty Cycle $\leq 2\%$.
4. Guaranteed by design, not subject to production
5. EAS condition : $T_J=25^\circ\text{C}, V_{DD}=40V, V_G=10V, L=0.5mH, R_G=25\Omega$

Typical Electrical and Thermal Characteristic Curves

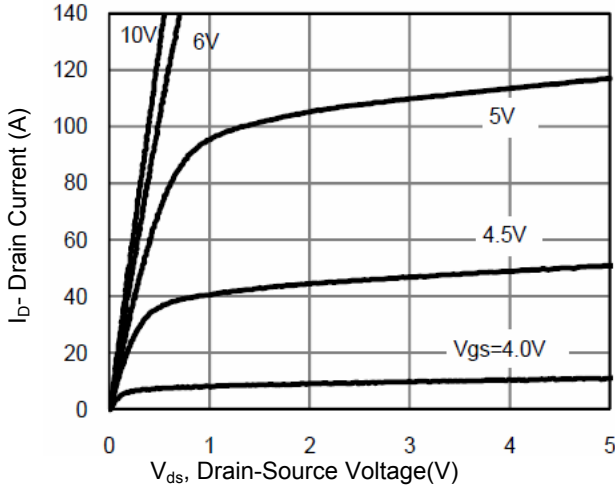

Figure 1. Output Characteristics

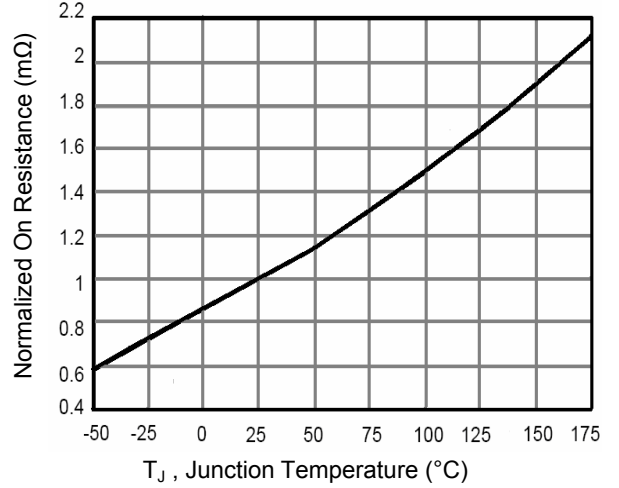

Figure 2. R_{dson} -Junction Temperature

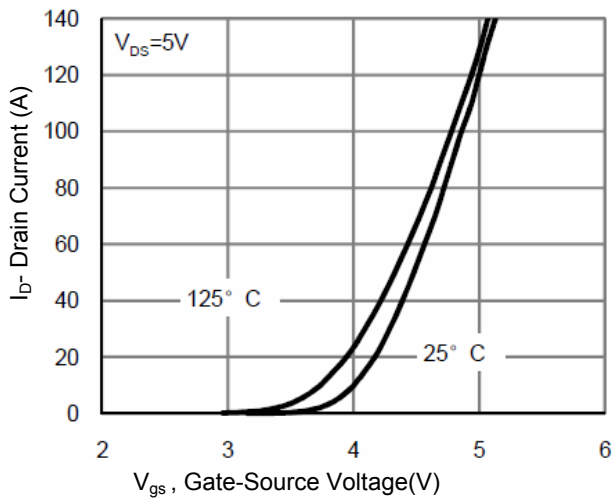

Figure 3. Transfer Characteristics

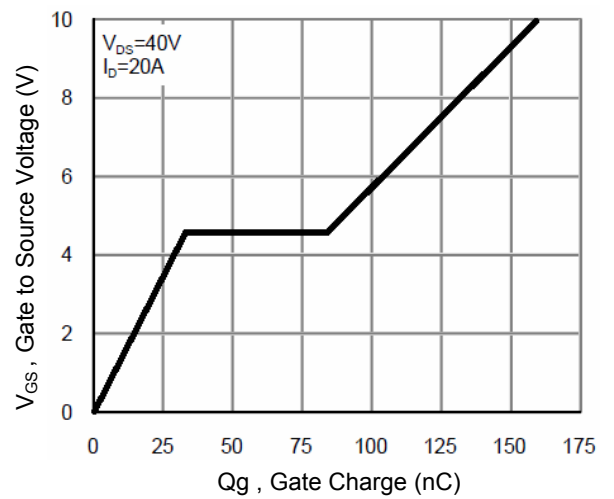

Figure 4. Gate Charge Characteristics

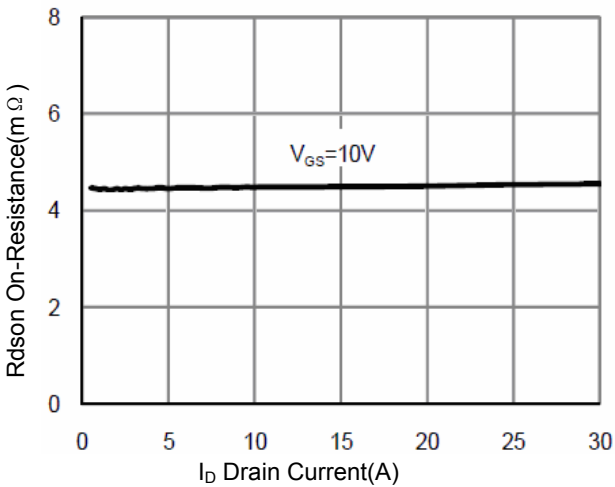

Figure 5. R_{dson} -Drain Current

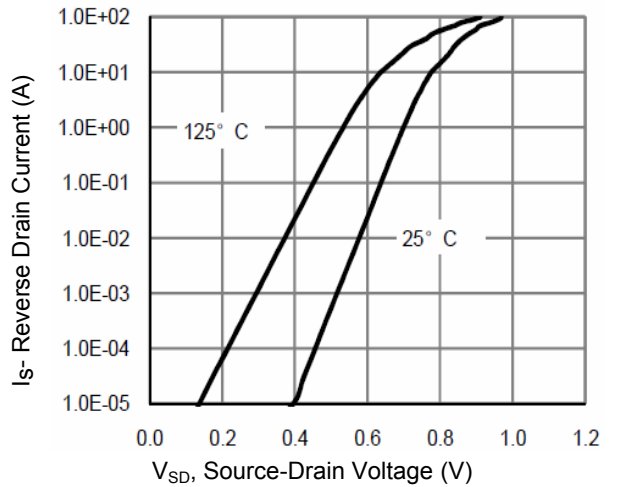

Figure 6. Source-Drain Diode Forward

Typical Electrical and Thermal Characteristic Curves

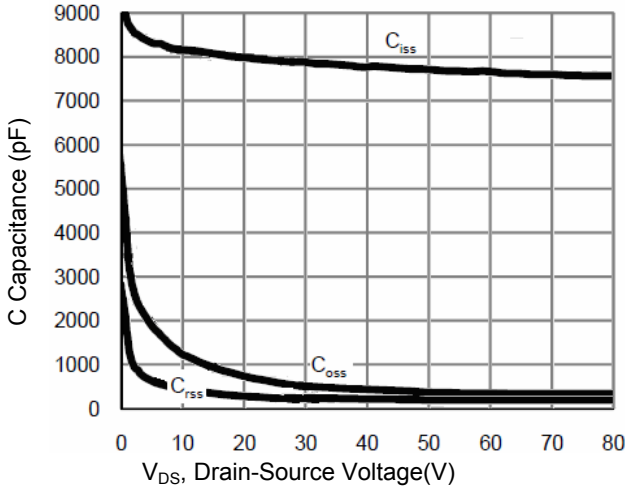

Figure 7. Capacitance vs. V_{DS}

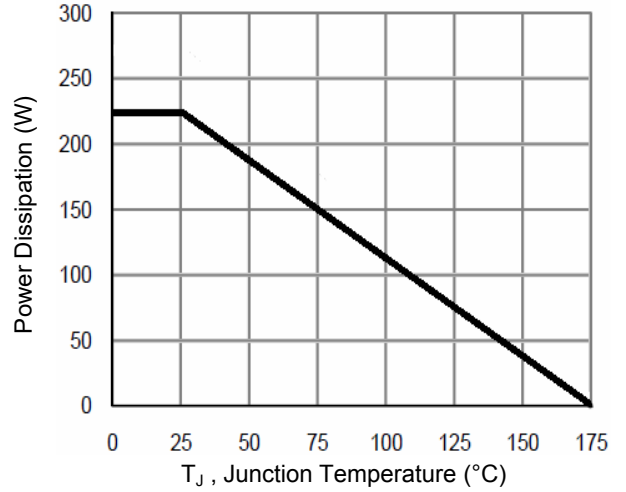

Figure 8. Power De-rating

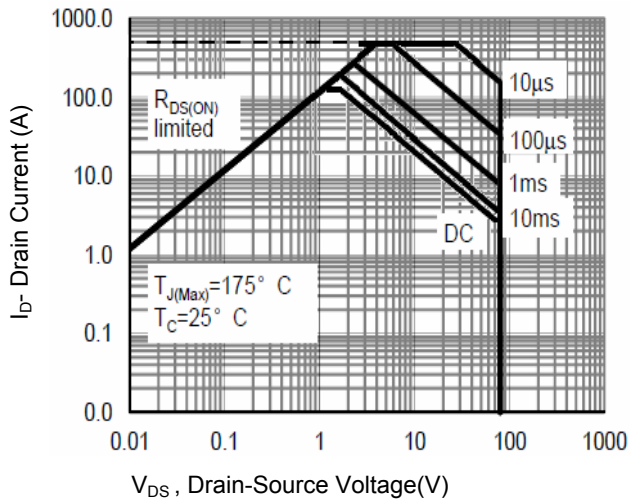

Figure 9. Safe Operation Area

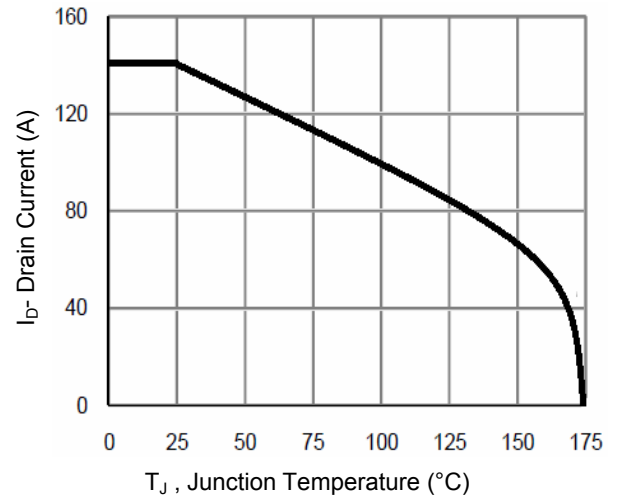

Figure 10. Current De-Rating

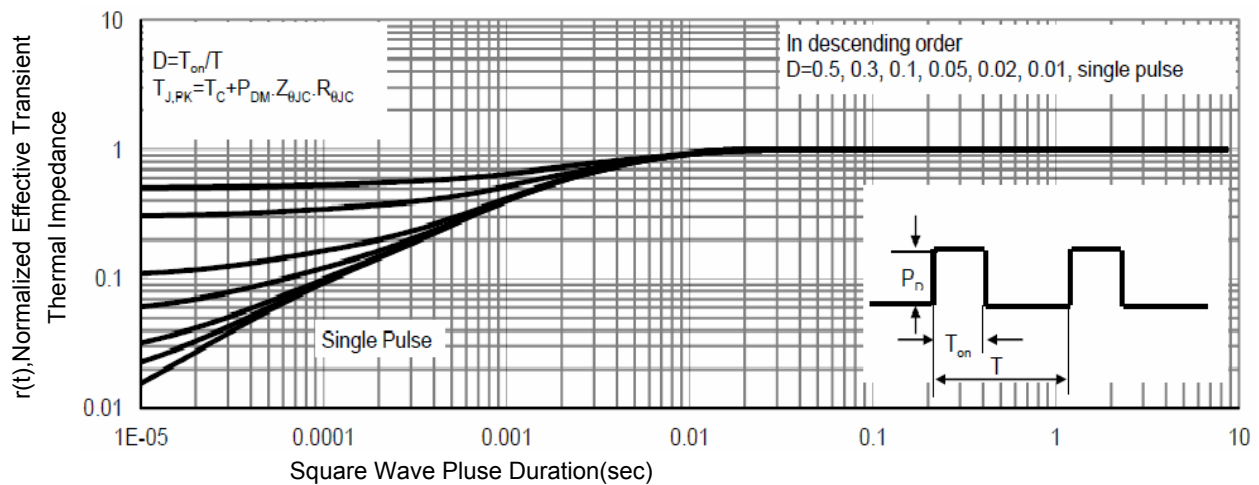

Figure 11. Normalized Maximum Transient Thermal Impedance

Typical Electrical and Thermal Characteristic Curves

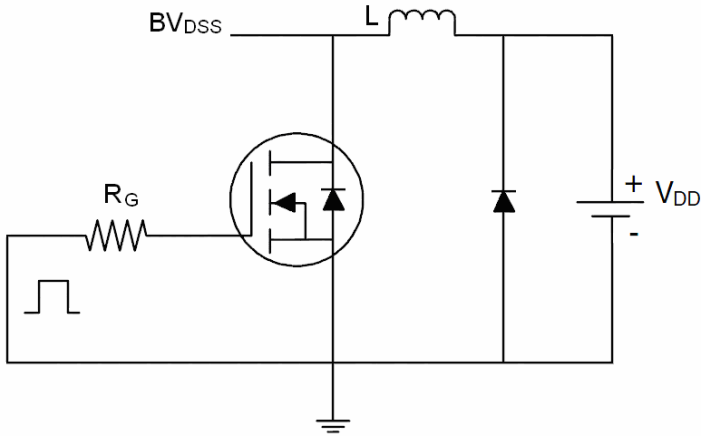

Figure 12. EAS Test Circuit

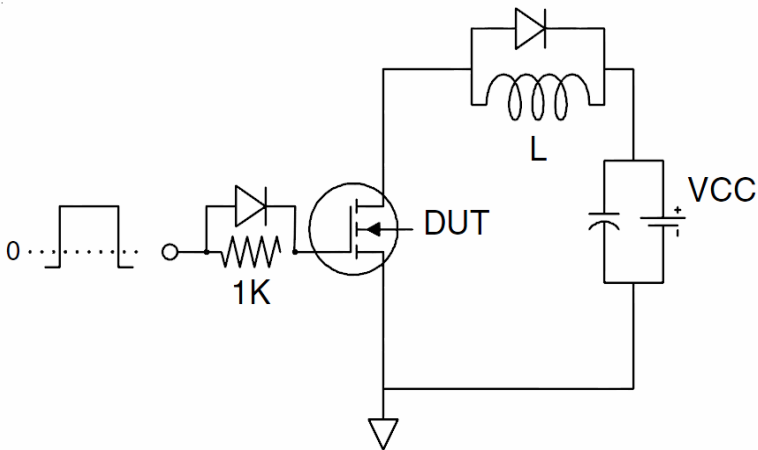

Figure 13. Gate Charge Test Circuit

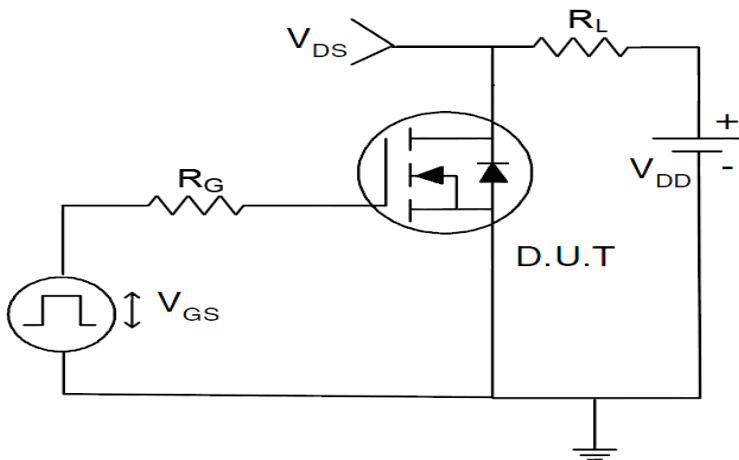
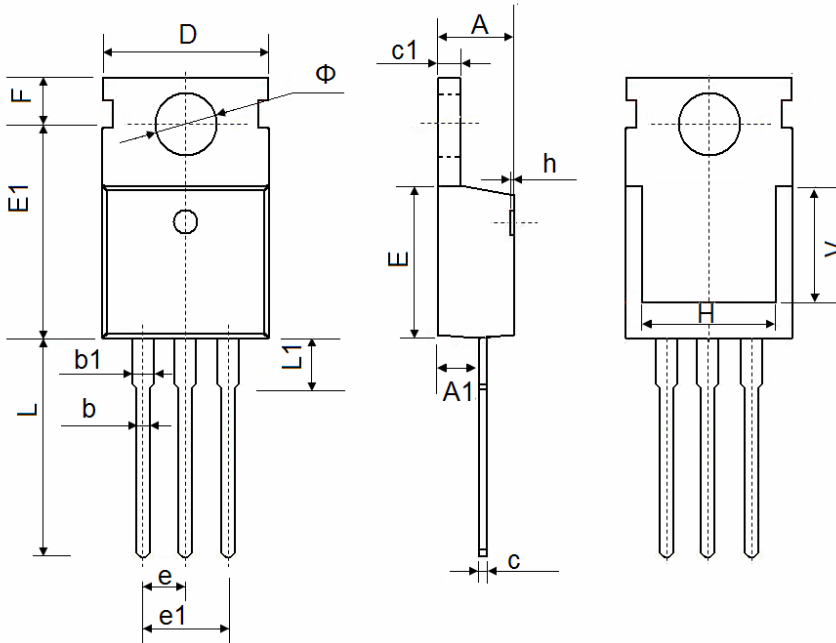

Figure 14. Switch Time Test Circuit

Package Outline Dimensions (TO-220)



Symbol	Dimensions In Millimeters		Dimensions In Inches	
	Min.	Max.	Min.	Max.
A	4.400	4.600	0.173	0.181
A1	2.250	2.550	0.089	0.100
b	0.710	0.910	0.028	0.036
b1	1.170	1.370	0.046	0.054
c	0.330	0.650	0.013	0.026
c1	1.200	1.400	0.047	0.055
D	9.910	10.250	0.390	0.404
E	8.9500	9.750	0.352	0.384
E1	12.650	12.950	0.498	0.510
e	2.540 TYP.		0.100 TYP.	
e1	4.980	5.180	0.196	0.204
F	2.650	2.950	0.104	0.116
H	7.900	8.100	0.311	0.319
h	0.000	0.300	0.000	0.012
L	12.900	13.400	0.508	0.528
L1	2.850	3.250	0.112	0.128
V	7.500 REF.		0.295 REF.	
Φ	3.400	3.800	0.134	0.150