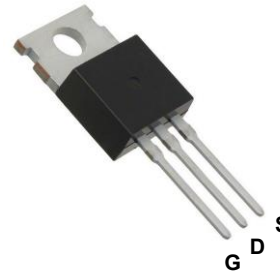
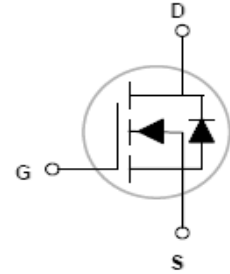


## Main Product Characteristics

$V_{DS}$	60V
$R_{DS(ON)}$	6.5m $\Omega$
$I_D$	100A



TO-220



Schematic Diagram

## Features and Benefits

- Advanced MOSFET process technology
- Ideal for high efficiency switched mode power supplies
- Low on-resistance with low gate charge
- Fast switching and reverse body recovery



## Description

The GSFH06100 utilizes the latest techniques to achieve high cell density and low on-resistance. These features make this device extremely efficient and reliable for use in high efficiency switch mode power supply and a wide variety of other applications.

## Absolute Maximum Ratings ( $T_C=25^{\circ}\text{C}$ unless otherwise specified)

Parameter	Symbol	Max.	Unit
Drain-Source Voltage	$V_{DS}$	60	V
Gate-Source Voltage	$V_{GS}$	$\pm 20$	V
Drain Current-Continuous	$I_D$	100	A
Drain Current-Continuous( $T_C=100^{\circ}\text{C}$ )	$I_{D(100^{\circ}\text{C})}$	70	A
Pulsed Drain Current	$I_{DM}$	320	A
Maximum Power Dissipation	$P_D$	170	W
Derating Factor		1.13	W/ $^{\circ}\text{C}$
Single Pulse Avalanche Energy <sup>5</sup>	$E_{AS}$	550	mJ
Thermal Resistance, Junction-to-Case <sup>2</sup>	$R_{\theta JC}$	0.88	$^{\circ}\text{C}/\text{W}$
Operating Junction Temperature Range	$T_J$	-55 To +175	$^{\circ}\text{C}$
Storage Temperature Range	$T_{STG}$	-55 To +175	$^{\circ}\text{C}$

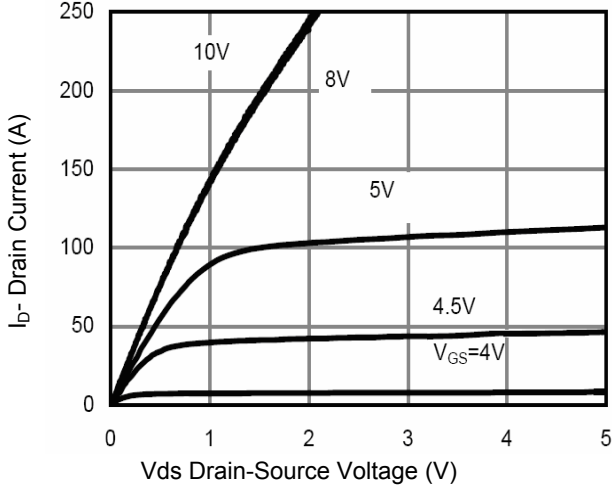
**Electrical Characteristics** ( $T_C=25^\circ\text{C}$  unless otherwise specified)

Parameter	Symbol	Conditions	Min.	Typ.	Max.	Unit
<b>Off Characteristics</b>						
Drain-Source Breakdown Voltage	$BV_{DSS}$	$V_{GS}=0V, I_D=250\mu A$	60	65	-	V
Zero Gate Voltage Drain Current	$I_{DSS}$	$V_{DS}=60V, V_{GS}=0V$	-	-	1	$\mu A$
Gate-Body Leakage Current	$I_{GSS}$	$V_{GS}=\pm 20V, V_{DS}=0V$	-	-	$\pm 100$	nA
<b>On Characteristics<sup>3</sup></b>						
Gate Threshold Voltage	$V_{GS(th)}$	$V_{DS}=V_{GS}, I_D=250\mu A$	2	3	4	V
Drain-Source On-State Resistance	$R_{DS(ON)}$	$V_{GS}=10V, I_D=40A$	-	5.7	6.5	m $\Omega$
Forward Transconductance	$g_{FS}$	$V_{DS}=10V, I_D=40A$	-	50	-	S
<b>Dynamic Characteristics<sup>4</sup></b>						
Input Capacitance	$C_{ISS}$	$V_{DS}=30V, V_{GS}=0V,$ $F=1.0MHz$	-	4800	-	PF
Output Capacitance	$C_{OSS}$		-	440	-	
Reverse Transfer Capacitance	$C_{RSS}$		-	260	-	
<b>Switching Characteristics<sup>4</sup></b>						
Total Gate Charge	$Q_g$	$V_{DS}=30V, I_D=30A,$ $V_{GS}=10V$	-	85	-	nC
Gate-Source Charge	$Q_{gs}$		-	18	-	
Gate-Drain Charge	$Q_{gd}$		-	28	-	
Turn-On Delay Time	$t_{d(on)}$	$V_{DD}=30V, I_D=1A,$ $V_{GS}=10V,$ $R_{GEN}=2.5\Omega$	-	16.8	-	nS
Turn-On Rise Time	$t_r$		-	10.8	-	
Turn-Off Delay Time	$t_{d(off)}$		-	55	-	
Turn-Off Fall Time	$t_f$		-	13.6	-	
<b>Drain-Source Diode Characteristics</b>						
Diode Forward Current <sup>2</sup>	$I_S$		-	-	90	A
Diode Forward Voltage <sup>3</sup>	$V_{SD}$	$I_S=20A, V_{GS}=0V$	-	-	1.2	V
Reverse Recovery Time	$t_{rr}$	$T_J=25^\circ\text{C}, I_F=40A$ $di/dt=-100A/\mu s^3$	-	38	-	nS
Reverse Recovery Charge	$Q_{rr}$		-	53	-	nC
Forward Turn-On Time	$t_{on}$	Intrinsic turn-on is negligible(turn-on is dominated by LS+LD)				

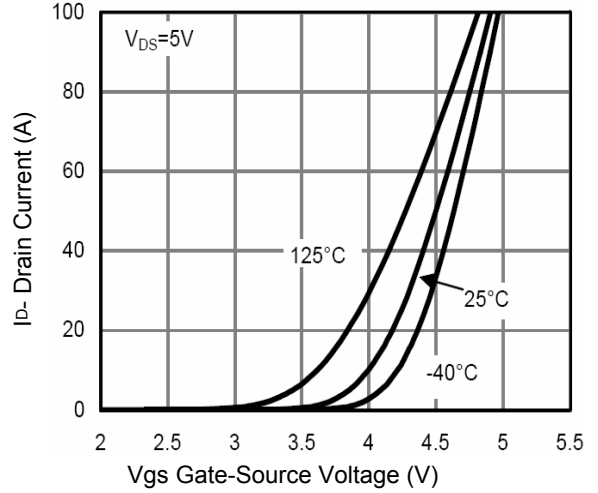
**Notes:**

1. Repetitive Rating: Pulse width limited by maximum junction temperature.
2. Surface Mounted on FR4 Board,  $t \leq 10$  sec.
3. Pulse Test: Pulse Width  $\leq 300\mu s$ , Duty Cycle  $\leq 2\%$ .
4. Guaranteed by design, not subject to production
5. EAS condition:  $T_J=25^\circ\text{C}, V_{DD}=30V, V_G=10V, L=0.5mH, R_G=25\Omega$

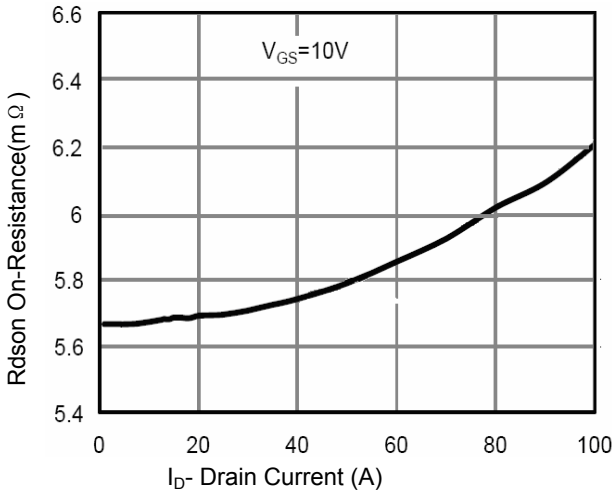
**Typical Electrical and Thermal Characteristic Curves**



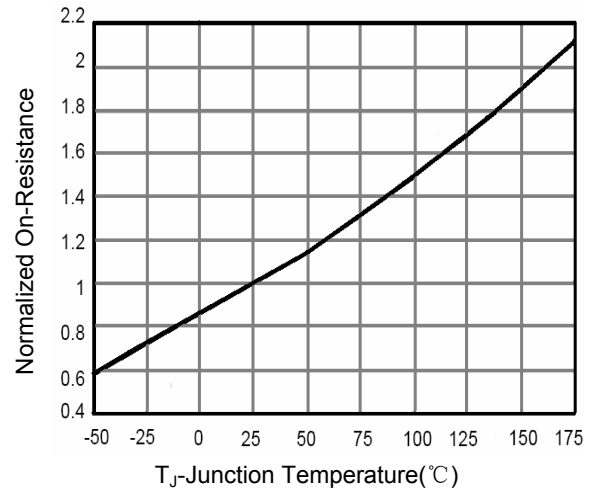
**Figure 1. Output Characteristics**



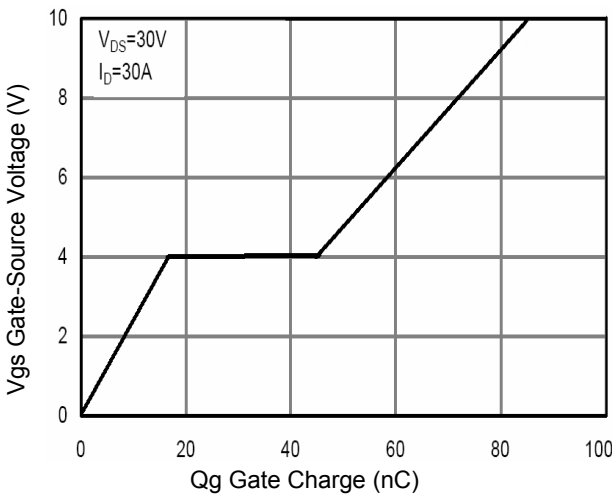
**Figure 2. Transfer Characteristics**



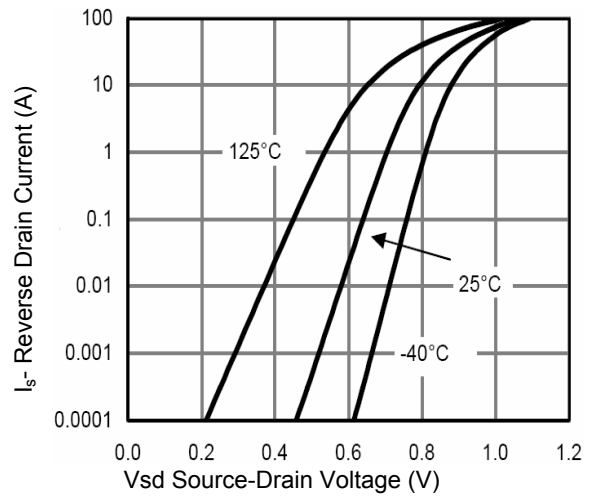
**Figure 3. Rdson- Drain Current**



**Figure 4. Rdson-Junction Temperature**

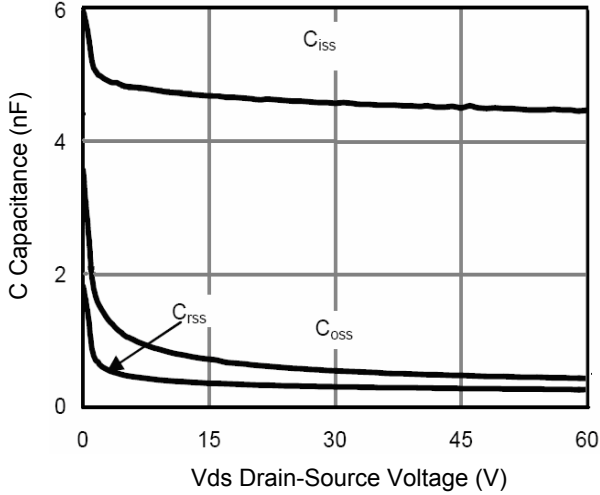


**Figure 5. Gate Charge**

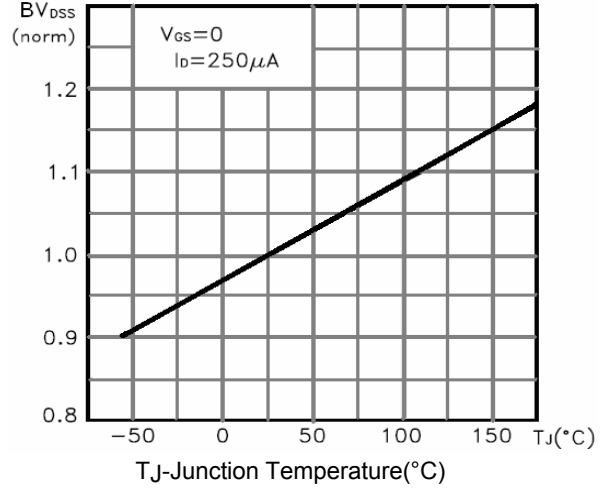


**Figure 6. Source- Drain Diode Forward**

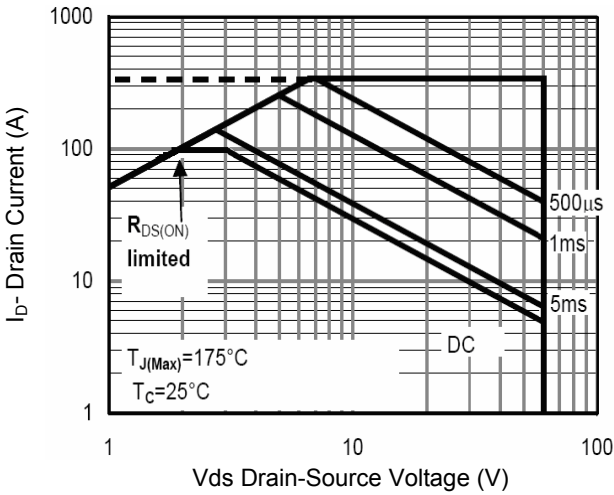
**Typical Electrical and Thermal Characteristic Curves**



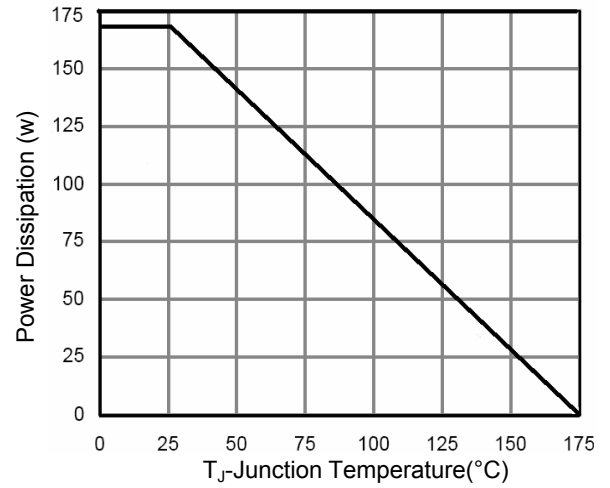
**Figure 7. Capacitance vs Vds**



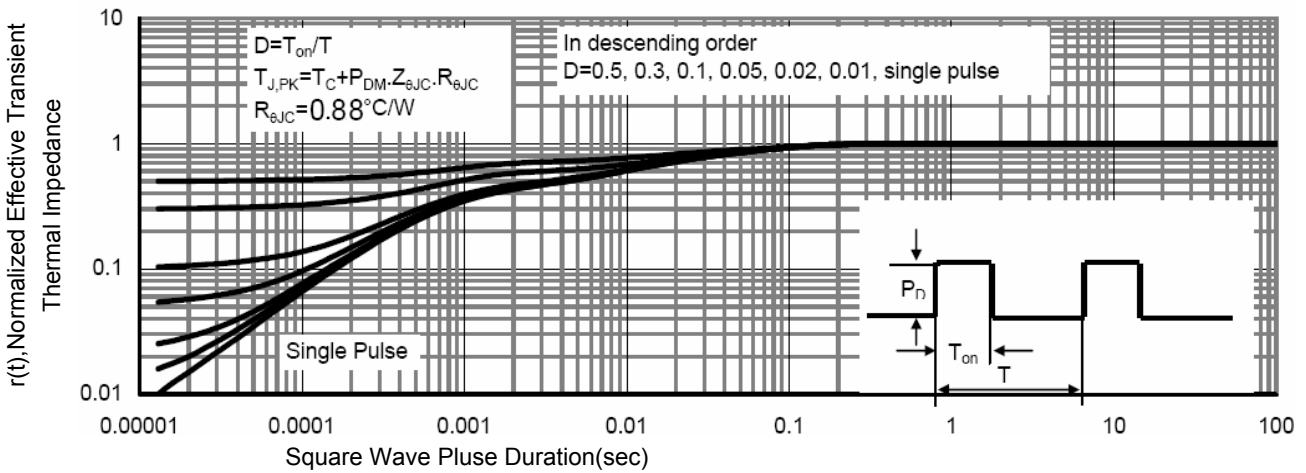
**Figure 8. BV<sub>DSS</sub> vs Junction Temperature**



**Figure 9. Safe Operation Area**

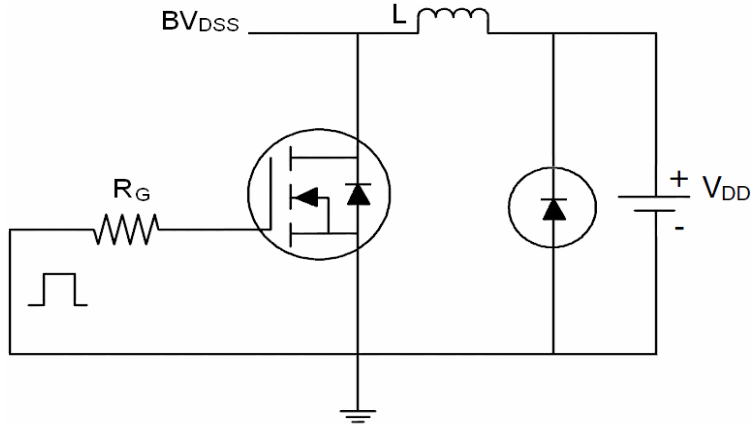


**Figure 10. Power De-rating**

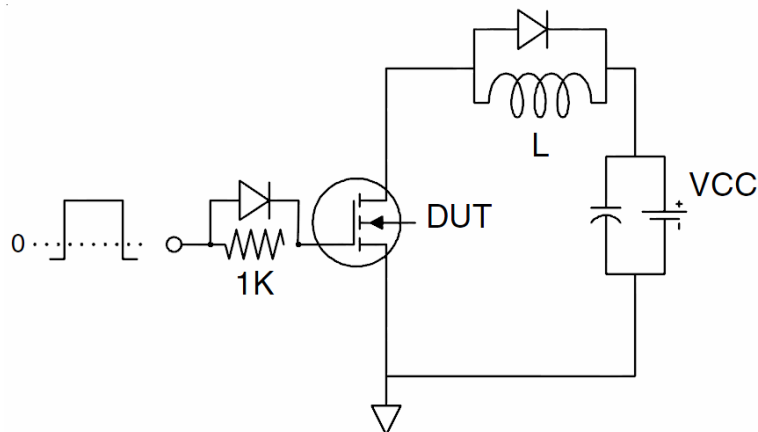


**Figure 11. Normalized Maximum Transient Thermal Impedance**

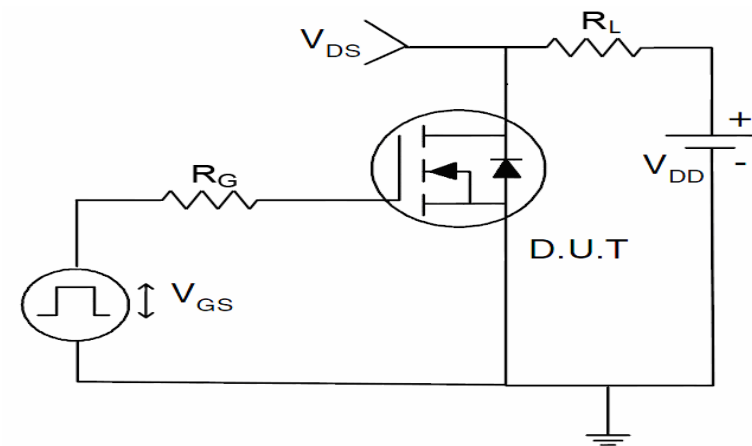
**Typical Electrical and Thermal Characteristic Curves**



**Figure 12.  $E_{AS}$  Test Circuit**

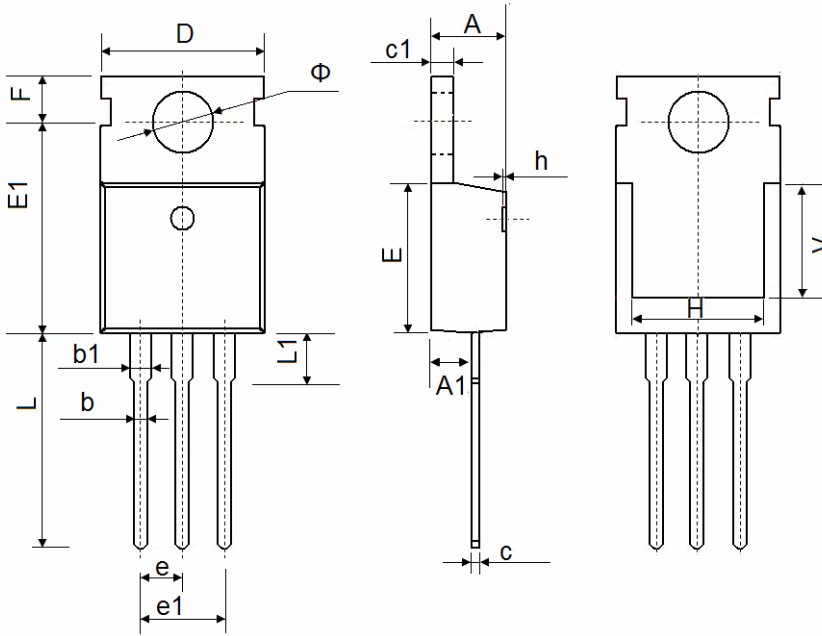


**Figure 13. Gate Charge Test Circuit**



**Figure 14. Switch Time Test Circuit**

**Package Outline Dimensions (TO-220)**



Symbol	Dimensions In Millimeters		Dimensions In Inches	
	Min.	Max.	Min.	Max.
A	4.400	4.600	0.173	0.181
A1	2.250	2.550	0.089	0.100
b	0.710	0.910	0.028	0.036
b1	1.170	1.370	0.046	0.054
c	0.330	0.650	0.013	0.026
c1	1.200	1.400	0.047	0.055
D	9.910	10.250	0.390	0.404
E	8.9500	9.750	0.352	0.384
E1	12.650	12.950	0.498	0.510
e	2.540 TYP.		0.100 TYP.	
e1	4.980	5.180	0.196	0.204
F	2.650	2.950	0.104	0.116
H	7.900	8.100	0.311	0.319
h	0.000	0.300	0.000	0.012
L	12.900	13.400	0.508	0.528
L1	2.850	3.250	0.112	0.128
V	7.500 REF.		0.295 REF.	
$\Phi$	3.400	3.800	0.134	0.150