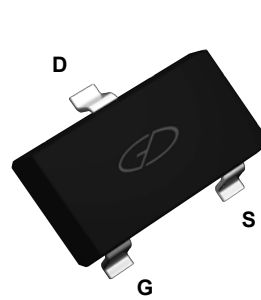
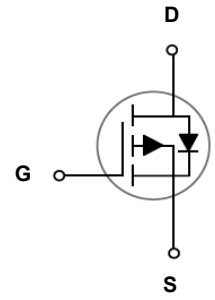


### Main Product Characteristics

$BV_{DSS}$	-20V
$R_{DS(ON)}$	160m $\Omega$
$I_D$	-2.5A



SOT-23



Schematic Diagram

### Features and Benefits

- Advanced MOSFET process technology
- Ideal for high efficiency switched mode power supplies
- Low on-resistance with low gate charge
- Fast switching and reverse body recovery



### Description

The GSFC0207 utilizes the latest techniques to achieve high cell density and low on-resistance. These features make this device extremely efficient and reliable for use in high efficiency switch mode power supply and a wide variety of other applications.

### Absolute Maximum Ratings ( $T_C=25^{\circ}C$ unless otherwise specified)

Parameter	Symbol	Max.	Unit
Drain-Source Voltage	$V_{DS}$	-20	V
Gate-Source Voltage	$V_{GS}$	$\pm 10$	V
Drain Current-Continuous ( $T_C=25^{\circ}C$ )	$I_D$	-2.5	A
Drain Current-Continuous ( $T_C=100^{\circ}C$ )		-1.6	
Drain Current-Pulsed <sup>1</sup>	$I_{DM}$	-10	A
Power Dissipation ( $T_C=25^{\circ}C$ )	$P_D$	1.56	W
Power Dissipation-Derate above 25 $^{\circ}C$		0.012	
Thermal Resistance, Junction-to-Ambient	$R_{\theta JA}$	80	$^{\circ}C/W$
Operating Junction Temperature Range	$T_J$	-55 To +150	$^{\circ}C$
Storage Temperature Range	$T_{STG}$	-55 To +150	$^{\circ}C$

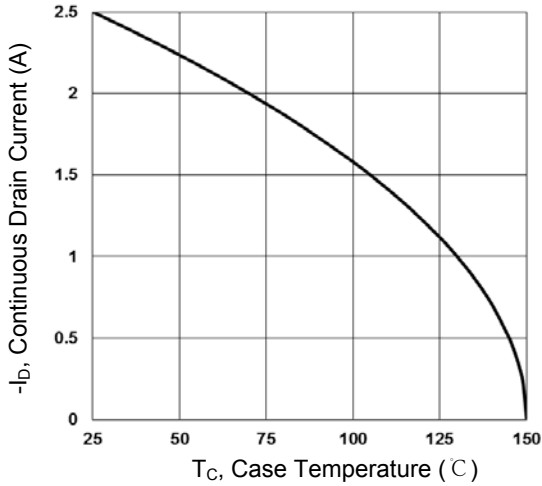
**Electrical Characteristics** ( $T_J=25^{\circ}\text{C}$  unless otherwise specified)

Parameter	Symbol	Conditions	Min.	Typ.	Max.	Unit
<b>On/Off Characteristics</b>						
Drain-Source Breakdown Voltage	$BV_{DSS}$	$V_{GS}=0V, I_D=-250\mu A$	-20	-	-	V
$BV_{DSS}$ Temperature Coefficient	$\Delta BV_{DSS}/\Delta T_J$	Reference to $25^{\circ}\text{C}$ , $I_D=-1mA$	-	-0.01	-	$V/^{\circ}\text{C}$
Drain-Source Leakage Current	$I_{DSS}$	$V_{DS}=-20V, V_{GS}=0V,$ $T_J=25^{\circ}\text{C}$	-	-	-1	$\mu A$
		$V_{DS}=-16V, V_{GS}=0V,$ $T_J=125^{\circ}\text{C}$	-	-	-10	$\mu A$
Gate-Source Leakage Current	$I_{GSS}$	$V_{GS}=\pm 10V, V_{DS}=0V$	-	-	$\pm 100$	nA
Static Drain-Source On-Resistance	$R_{DS(ON)}$	$V_{GS}=-4.5V, I_D=-2.5A$	-	120	160	m $\Omega$
		$V_{GS}=-2.5V, I_D=-2A$	-	170	230	
		$V_{GS}=-1.8V, I_D=-1A$	-	240	320	
Gate Threshold Voltage	$V_{GS(th)}$	$V_{GS}=V_{DS}, I_D=-250\mu A$	-0.3	-0.6	-1.0	V
$V_{GS(th)}$ Temperature Coefficient	$\Delta V_{GS(th)}$		-	3	-	mV/ $^{\circ}\text{C}$
<b>Dynamic and Switching Characteristics</b>						
Total Gate Charge <sup>2,3</sup>	$Q_g$	$V_{DS}=-10V, I_D=-1A,$ $V_{GS}=-4.5V$	-	2.5	5	nC
Gate-Source Charge <sup>2,3</sup>	$Q_{gs}$		-	0.36	0.72	
Gate-Drain Charge <sup>2,3</sup>	$Q_{gd}$		-	0.5	1.0	
Turn-On Delay Time <sup>2,3</sup>	$t_{d(on)}$	$V_{DD}=-10V, R_G=25\Omega,$ $V_{GS}=-4.5V, I_D=-1A$	-	2	4	nS
Rise Time <sup>2,3</sup>	$t_r$		-	7.8	15	
Turn-Off Delay Time <sup>2,3</sup>	$t_{d(off)}$		-	16.6	32	
Fall Time <sup>2,3</sup>	$t_f$		-	4.5	9	
Input Capacitance	$C_{iss}$	$V_{DS}=-15V, V_{GS}=0V,$ $F=1MHz$	-	150	300	pF
Output Capacitance	$C_{oss}$		-	32	64	
Reverse Transfer Capacitance	$C_{rss}$		-	23	46	
<b>Drain-Source Diode Characteristics and Maximum Ratings</b>						
Continuous Source Current	$I_S$	$V_G=V_D=0V,$ Force Current	-	-	-2.5	A
Pulsed Source Current	$I_{SM}$		-	-	-5	A
Diode Forward Voltage	$V_{SD}$	$V_{GS}=0V, I_S=-1A,$ $T_J=25^{\circ}\text{C}$	-	-	-1	V

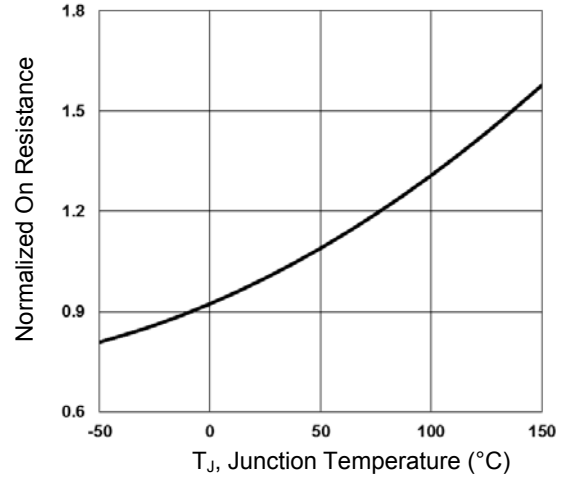
Note:

1. Repetitive rating: Pulsed width limited by maximum junction temperature.
2. Pulse test: pulse width  $\leq 300\mu s$ , duty cycle  $\leq 2\%$ .
3. Essentially independent of operation temperature.

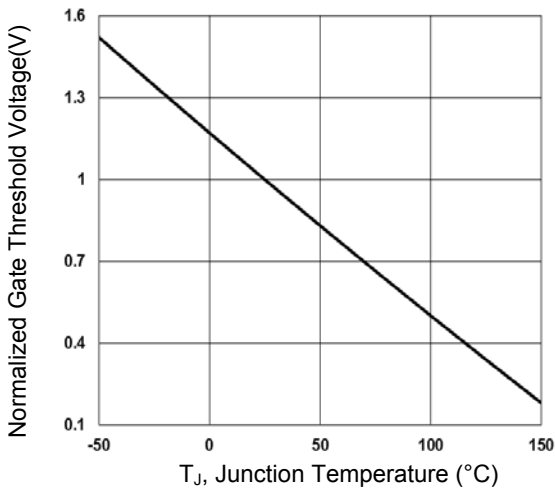
**Typical Electrical and Thermal Characteristic Curves**



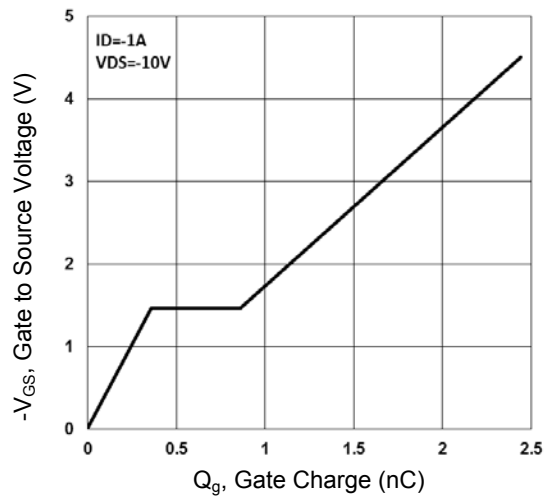
**Figure 1. Continuous Drain Current vs.  $T_c$**



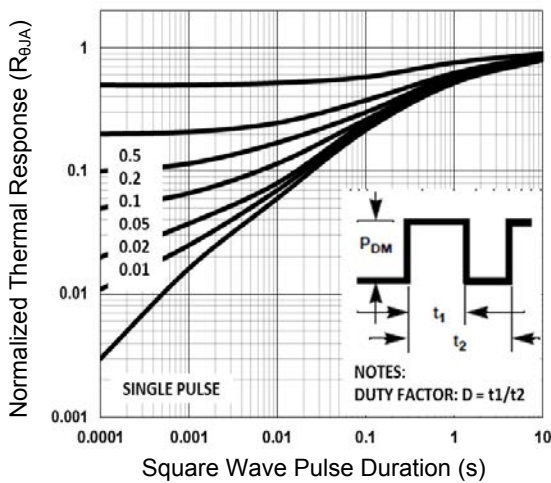
**Figure 2. Normalized  $R_{DSON}$  vs.  $T_j$**



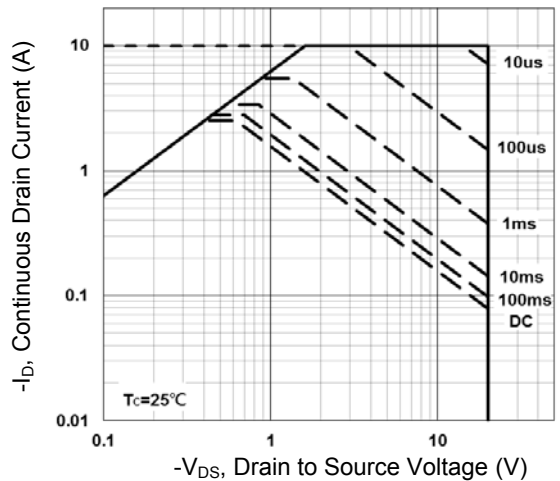
**Figure 3. Normalized  $V_{th}$  vs.  $T_j$**



**Figure 4. Gate Charge Waveform**

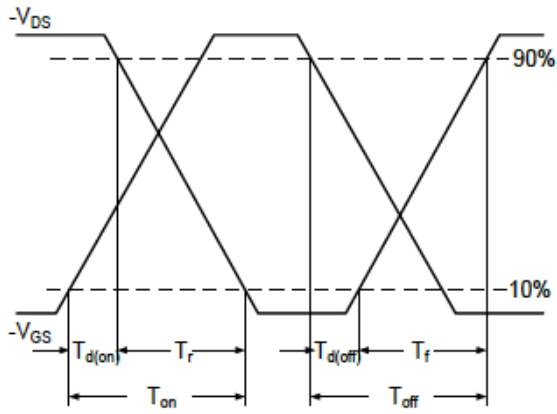


**Figure 5. Normalized Transient Impedance**

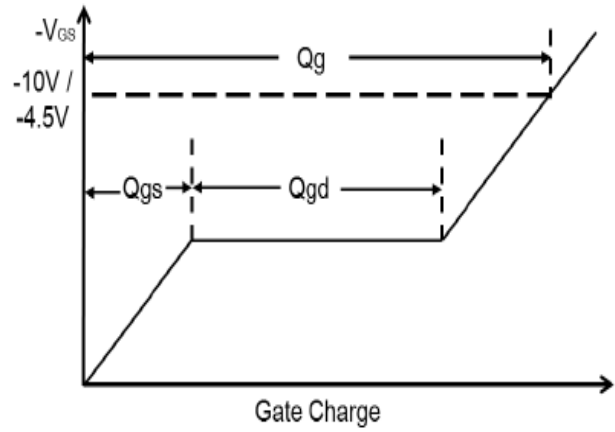


**Figure 6. Maximum Safe Operation Area**

**Typical Electrical and Thermal Characteristic Curves**

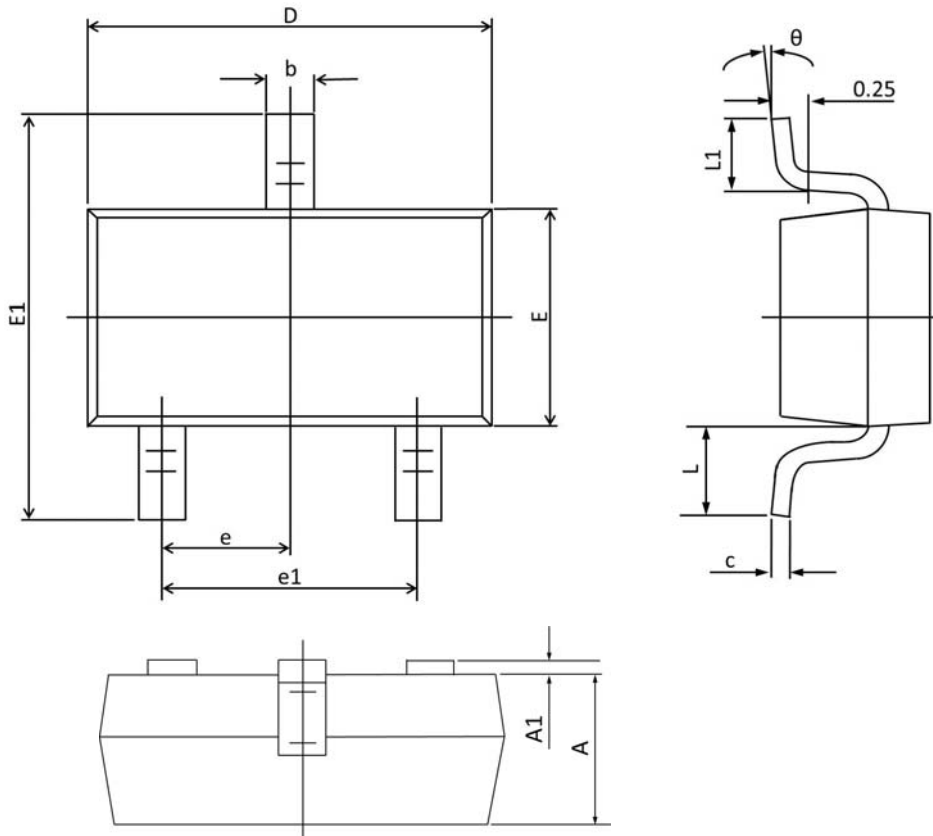


**Figure 7. Switching Time Waveform**



**Figure 8. Gate Charge Waveform**

**Package Outline Dimensions (SOT-23)**



Symbol	Dimensions In Millimeters		Dimensions In Inches	
	Min	Max	Min	Max
A	0.900	1.000	0.035	0.039
A1	0.000	0.100	0.000	0.004
b	0.300	0.500	0.012	0.020
c	0.090	0.110	0.003	0.004
D	2.800	3.000	0.110	0.118
E	1.200	1.400	0.047	0.055
E1	2.250	2.550	0.089	0.100
e	0.950 TYP.		0.037 TYP.	
e1	1.800	2.000	0.071	0.079
L	0.550 REF.		0.022 REF.	
L1	0.300	0.500	0.012	0.020
θ	1°	7°	1°	7°