

Main Product Characteristics

BV_{DSS}	-20V
$R_{DS(ON)}$	600m Ω (Max.)
I_D	-450mA

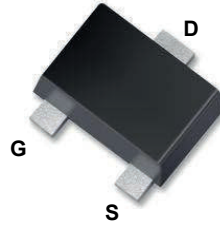

SOT-723

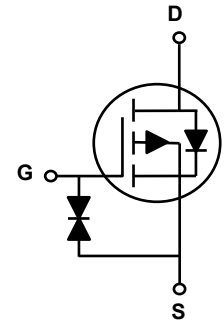

Schematic Diagram

Features and Benefits

- Advanced MOSFET process technology
- Ideal for high efficiency switched mode power supplies
- Low on-resistance with low gate charge
- Fast switching and reverse body recovery



Description

The GSF2319K utilizes the latest techniques to achieve high cell density and low on-resistance. These features make this device extremely efficient and reliable for use in high efficiency switch mode power supplies and a wide variety of other applications.

Absolute Maximum Ratings ($T_A=25^\circ\text{C}$ unless otherwise specified)

Parameter	Symbol	Value	Units
Drain-Source Voltage	V_{DS}	-20	V
Gate-Source Voltage	V_{GS}	± 10	V
Drain Current-Continuous ($T_C=25^\circ\text{C}$)	I_D	-450	mA
Drain Current-Continuous ($T_C=100^\circ\text{C}$)		-280	mA
Drain Current-Pulsed ¹	I_{DM}	-1.8	A
Power Dissipation ($T_C=25^\circ\text{C}$)	P_D	312	mW
Power Dissipation-Derate above 25 $^\circ\text{C}$		2.5	mW/ $^\circ\text{C}$
Max. Thermal Resistance Junction to Ambient	$R_{\theta JA}$	400	$^\circ\text{C}/\text{W}$
Storage Temperature Range	T_{STG}	-55 to +150	$^\circ\text{C}$
Operating Junction Temperature Range	T_J	-55 to +150	$^\circ\text{C}$

Electrical Characteristics ($T_J=25^\circ\text{C}$ unless otherwise specified)

Parameter	Symbol	Conditions	Min.	Typ.	Max.	Unit
On / Off Characteristics						
Drain-Source Breakdown Voltage	BV_{DSS}	$V_{GS}=0V, I_D=-250\mu A$	-20	-	-	V
BV_{DSS} Temperature Coefficient	$\Delta BV_{DSS}/\Delta T_J$	Reference to 25°C , $I_D=-1\text{mA}$	-	-0.01	-	$V/^\circ\text{C}$
Drain-Source Leakage Current	I_{DSS}	$V_{DS}=-20V, V_{GS}=0V, T_J=25^\circ\text{C}$	-	-	-1	μA
		$V_{DS}=-16V, V_{GS}=0V, T_J=125^\circ\text{C}$	-	-	-10	μA
Gate-Source Leakage Current	I_{GSS}	$V_{GS}=\pm 8V, V_{DS}=0V$	-	-	± 20	μA
Static Drain-Source On-Resistance	$R_{DS(ON)}$	$V_{GS}=-4.5V, I_D=-0.3A$	-	440	600	m Ω
		$V_{GS}=-2.5V, I_D=-0.2A$	-	610	850	
		$V_{GS}=-1.8V, I_D=-0.1A$	-	810	1200	
Gate Threshold Voltage	$V_{GS(th)}$	$V_{GS}=V_{DS}, I_D=-250\mu A$	-0.3	-0.6	-1.0	V
$V_{GS(th)}$ Temperature Coefficient	$\Delta V_{GS(th)}$		-	3	-	$\text{mV}/^\circ\text{C}$
Dynamic and Switching Characteristics						
Total Gate Charge ^{2,3}	Q_g	$V_{DS}=-10V, V_{GS}=-4.5V, I_D=-0.2A$	-	1	2	nC
Gate-Source Charge ^{2,3}	Q_{gs}		-	0.28	0.5	
Gate-Drain Charge ^{2,3}	Q_{gd}		-	0.18	0.4	
Turn-On Delay Time ^{2,3}	$t_{d(on)}$	$V_{DD}=-10V, V_{GS}=-4.5V, R_G=10\Omega, I_D=-0.2A$	-	8	16	nS
Rise Time ^{2,3}	t_r		-	5.2	10	
Turn-Off Delay Time ^{2,3}	$t_{d(off)}$		-	30	60	
Fall Time ^{2,3}	t_f		-	18	36	
Input Capacitance	C_{iss}	$V_{DS}=-10V, V_{GS}=0V, F=1\text{MHz}$	-	40	78	pF
Output Capacitance	C_{oss}		-	15	30	
Reverse Transfer Capacitance	C_{rss}		-	6.5	13	
Drain-Source Ratings and Characteristics						
Continuous Source Current	I_S	$V_G=V_D=0V, \text{Force Current}$	-	-	-0.45	A
Pulsed Source Current	I_{SM}		-	-	-0.9	A
Diode Forward Voltage	V_{SD}	$V_{GS}=0V, I_S=-0.2A, T_J=25^\circ\text{C}$	-	-	-1	V

Notes:

1. Repetitive rating: Pulsed width limited by maximum junction temperature.
2. The data tested by pulsed, pulse width $\leq 300\mu s$, duty cycle $\leq 2\%$.
3. Essentially independent of operating temperature.

Typical Electrical and Thermal Characteristic Curves

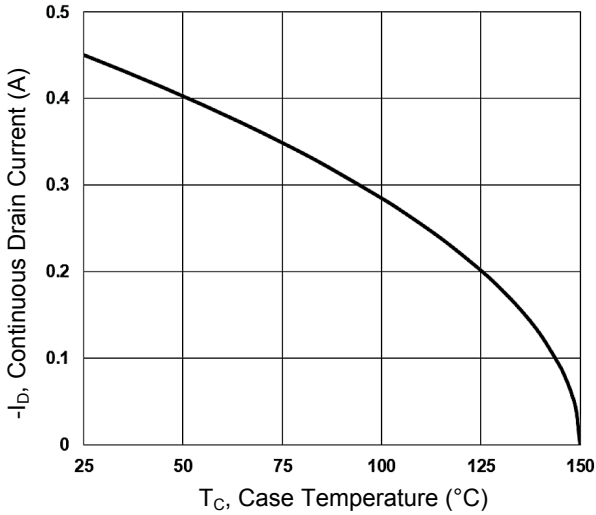

Figure 1. Continuous Drain Current vs. T_c

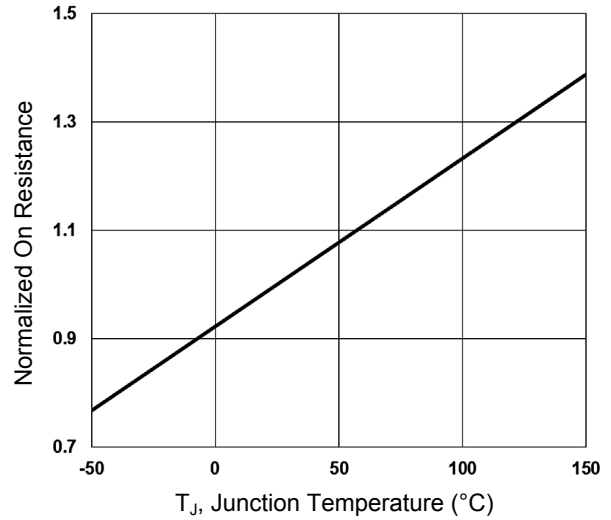

Figure 2. Normalized R_{DSON} vs. T_j

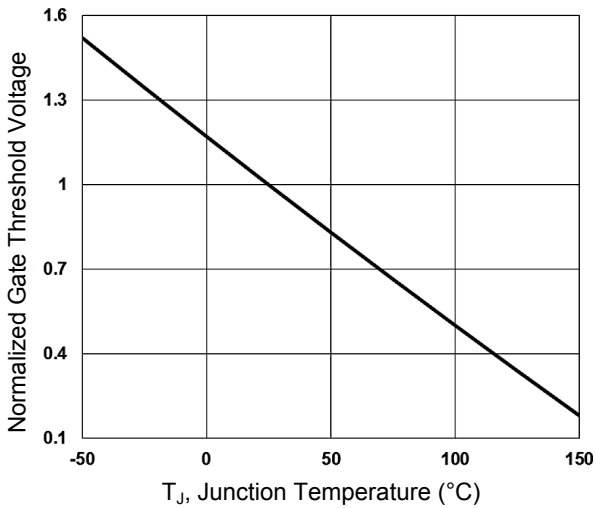

Figure 3. Normalized $V_{GS(th)}$ vs. T_j

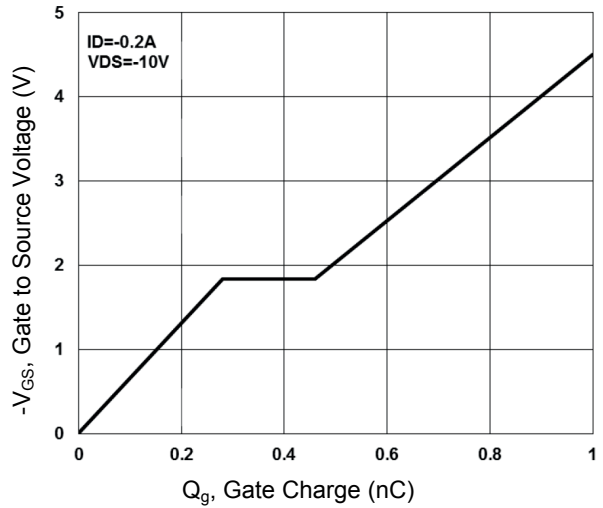

Figure 4. Gate Charge Waveform

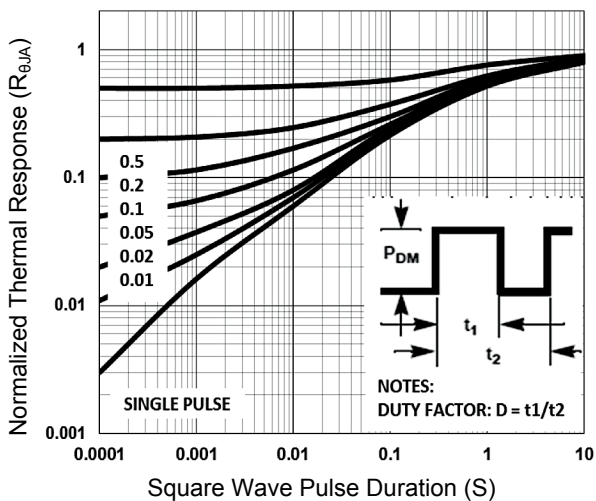

Figure 5. Normalized Transient Impedance

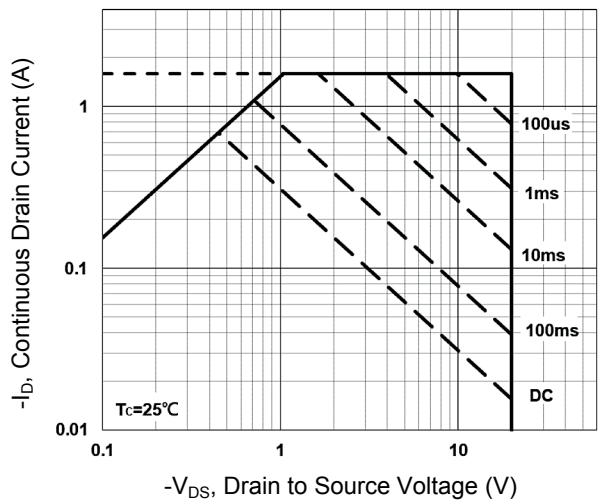
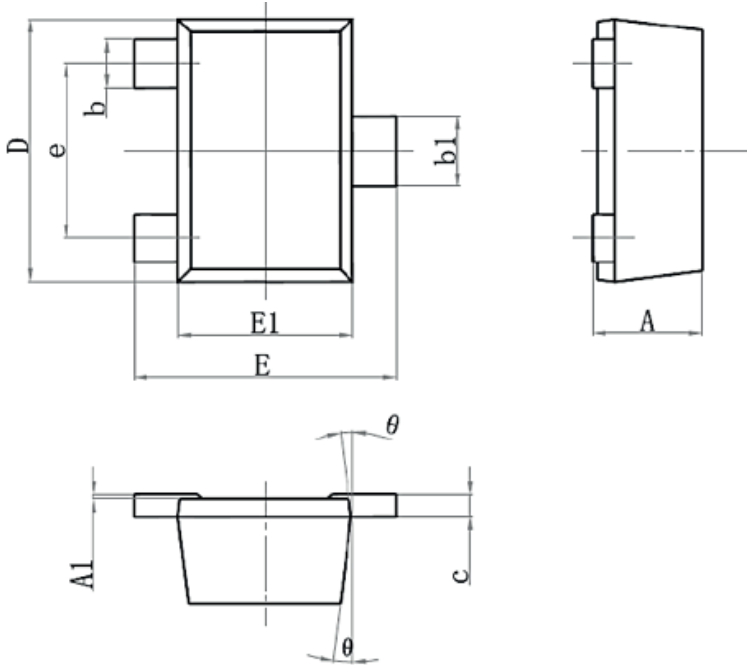

Figure 6. Maximum Safe Operation Area

Package Outline Dimensions (SOT-723)



Symbol	Dimensions In Millimeters		Dimensions In Inches	
	Min.	Max.	Min.	Max.
A	0.430	0.500	0.017	0.020
A1	0.000	0.050	0.000	0.002
b	0.170	0.270	0.007	0.011
b1	0.270	0.370	0.011	0.015
c	0.080	0.150	0.003	0.006
D	1.150	1.250	0.045	0.049
E	1.150	1.250	0.045	0.049
E1	0.750	0.850	0.030	0.033
e	0.800 TYP		0.031 TYP	
θ	7° REF		7° REF	

Order Information

Device	Package	Marking	Packaging	SPQ
GSF2319K	SOT-723	3	Tape & Reel	8,000 pcs / Reel