

Main Product Characteristics

$V_{(BR)DSS}$	900V
$R_{DS(ON)}$	3.5Ω (Max.)
I_D	4A

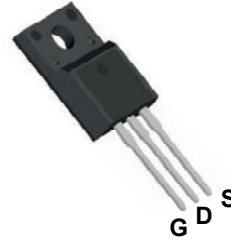

TO-220F

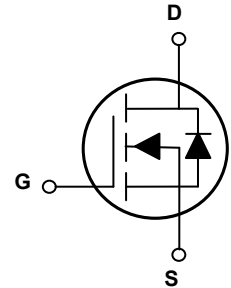

Schematic Diagram

Features and Benefits

- Advanced MOSFET process technology
- Ideal for high efficiency switched mode power supplies
- Low on-resistance with low gate charge
- Fast switching and reverse body recovery



Description

The GSJU4N90 utilizes the latest techniques to achieve high cell density and low on-resistance. These features make this device extremely efficient and reliable for use in high efficiency switch mode power supplies and a wide variety of other applications.

Absolute Maximum Ratings ($T_C=25^\circ\text{C}$ unless otherwise specified)

Parameter	Symbol	Parameter	Unit
Drain-Source Voltage	V_{DS}	900	V
Gate-to-Source Voltage	V_{GS}	±30	V
Continuous Drain Current, @ Steady-State ($T_C=25^\circ\text{C}$)	I_D	4	A
Continuous Drain Current, @ Steady-State ($T_C=100^\circ\text{C}$)		2.5	A
Pulsed Drain Current	I_{DM}	16	A
Power Dissipation ($T_C=25^\circ\text{C}$)	P_D	44	W
		0.35	W/°C
Single Pulse Avalanche Energy ¹	E_{AS}	344	mJ
Junction-to-Ambient (PCB Mounted, Steady-State)	$R_{\theta JA}$	62.5	°C/W
Junction-to-Case	$R_{\theta JC}$	2.84	°C/W
Operating Junction and Storage Temperature Range	T_J/T_{STG}	-55 to +150	°C

Electrical Characteristics ($T_C=25^\circ\text{C}$ unless otherwise specified)

Parameter	Symbol	Conditions	Min.	Typ.	Max.	Unit
On / Off Characteristics						
Drain-to-Source Breakdown Voltage	$V_{(BR)DSS}$	$V_{GS}=0V, I_D=250\mu A$	900	-	-	V
Drain-to-Source Leakage Current	I_{DSS}	$V_{DS}=900V, V_{GS}=0V$	-	-	1.0	μA
Gate-to-Source Forward Leakage	I_{GSS}	$V_{DS}=0V, V_{GS}=30V$	-	-	100	nA
		$V_{DS}=0V, V_{GS}=-30V$	-	-	-100	
Static Drain-to-Source On-Resistance	$R_{DS(ON)}$	$V_{GS}=10V, I_D=2A, T_J=25^\circ\text{C}$	-	2.7	3.5	Ω
		$V_{GS}=10V, I_D=2A, T_J=125^\circ\text{C}$	-	4.9	-	Ω
Gate Threshold Voltage	$V_{GS(th)}$	$V_{DS}=V_{GS}, I_D=250\mu A$	2.0	-	4.0	V
Dynamic and Switching Characteristics						
Input Capacitance	C_{iss}	$V_{GS}=0V, V_{DS}=25V, f=1\text{MHz}$	-	707	-	pF
Output Capacitance	C_{oss}		-	68	-	
Reverse Transfer Capacitance	C_{rss}		-	3.0	-	
Total Gate Charge ^{2,3}	Q_g	$I_D=4A, V_{DD}=720V, V_{GS}=10V$	-	17	-	nC
Gate-to-Source Charge ^{2,3}	Q_{gs}		-	4.1	-	
Gate-to-Drain ("Miller") Charge ^{2,3}	Q_{gd}		-	7.6	-	
Turn-on Delay Time ^{2,3}	$t_{d(on)}$	$V_{DD}=450V, R_G=25\Omega, I_D=4A$	-	15	-	nS
Rise Time ^{2,3}	t_r		-	26	-	
Turn-Off Delay Time ^{2,3}	$t_{d(off)}$		-	39	-	
Fall Time ^{2,3}	t_f		-	28	-	
Gate Resistance	R_g	$f=1\text{MHz}$	-	4.2	-	Ω
Source-Drain Ratings and Characteristics						
Continuous Source Current (Body Diode)	I_S	$T_C=25^\circ\text{C}$, MOSFET symbol showing the integral reverse p-n junction diode.	-	-	4	A
Source Pulse Current	I_{SM}		-	-	16	A
Diode Forward Voltage	V_{SD}	$I_S=4A, V_{GS}=0V$	-	-	1.4	V
Reverse Recovery Time	T_{rr}	$I_S=4A, V_{GS}=0V, dI_F/dt=100A/\mu s$	-	535	-	nS
Reverse Recovery Charge	Q_{rr}		-	2.5	-	μC

Notes:

1. $L=79\text{mH}, I_{AS}=2.6A, V_{DD}=100V$, starting temperature $T_J=25^\circ\text{C}$.
2. Pulse test : Pulse width $\leq 300\mu s$, duty cycle $\leq 2\%$.
3. Essentially independent of operating temperature.

Typical Electrical and Thermal Characteristic Curves

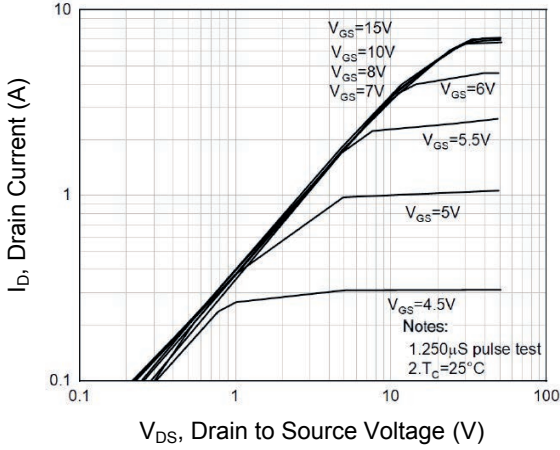

Figure 1. Typical Output Characteristics

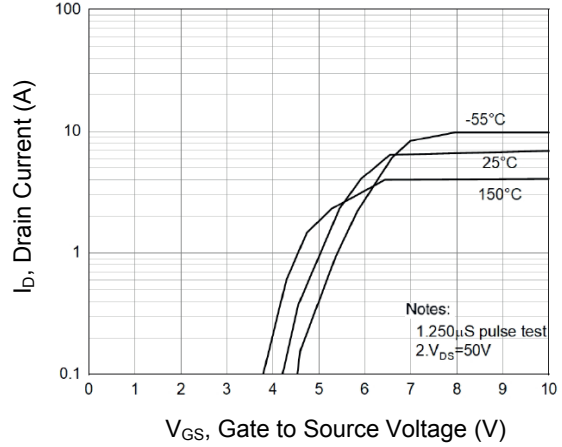

Figure 2. Transfer Characteristics

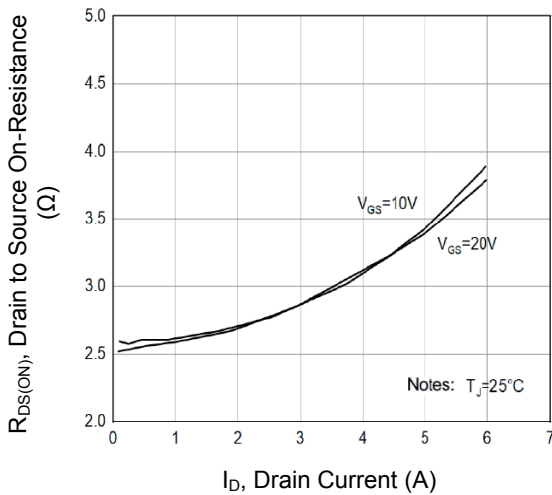

Figure 3. $R_{DS(ON)}$ vs. Drain Current

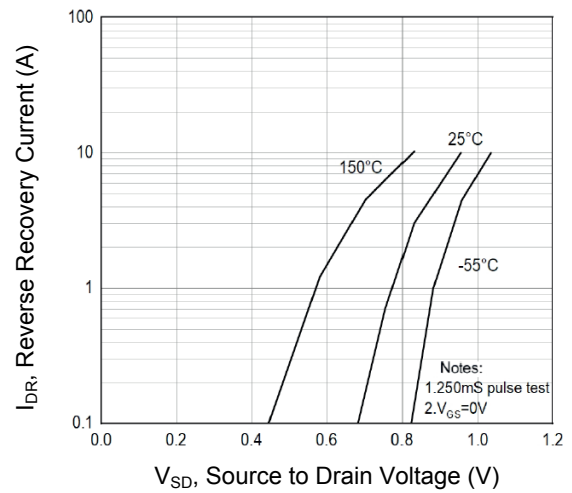

Figure 4. Body Diode Characteristics

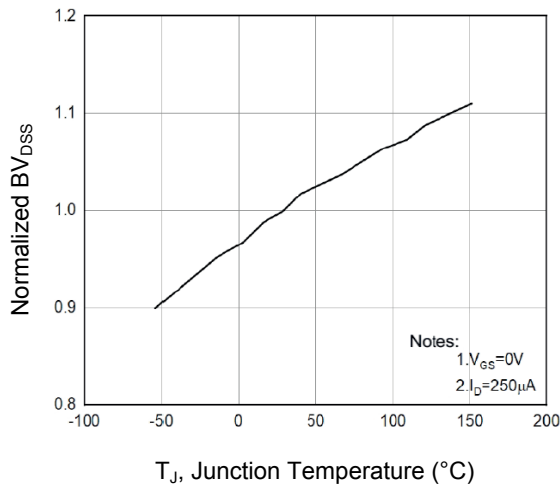

Figure 5. Normalized BV_{DS} vs. T_J

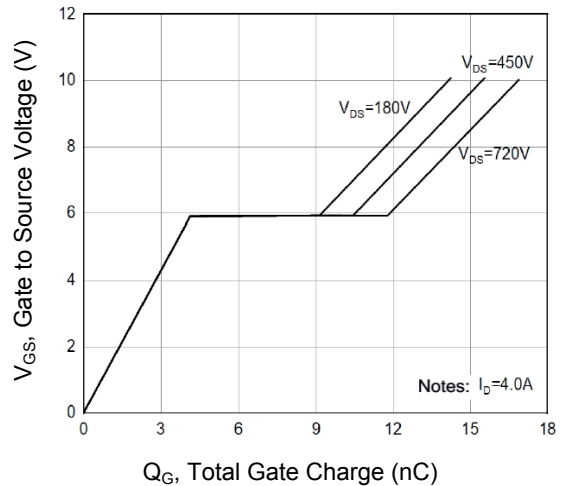

Figure 6. Gate Charge

Typical Electrical and Thermal Characteristic Curves

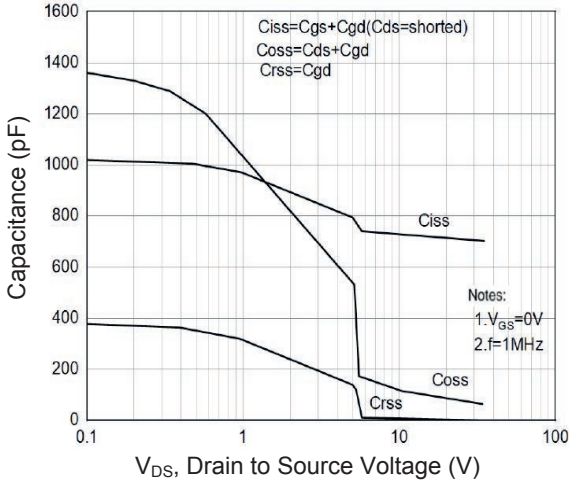

Figure 7. Capacitance Characteristics

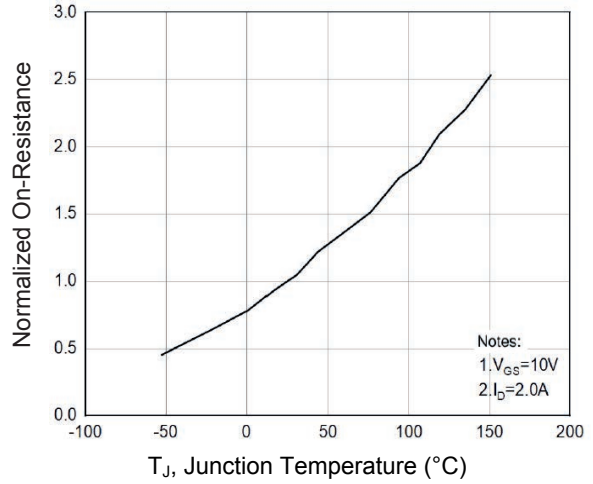

Figure 8. Normalized $R_{DS(ON)}$ vs. T_J

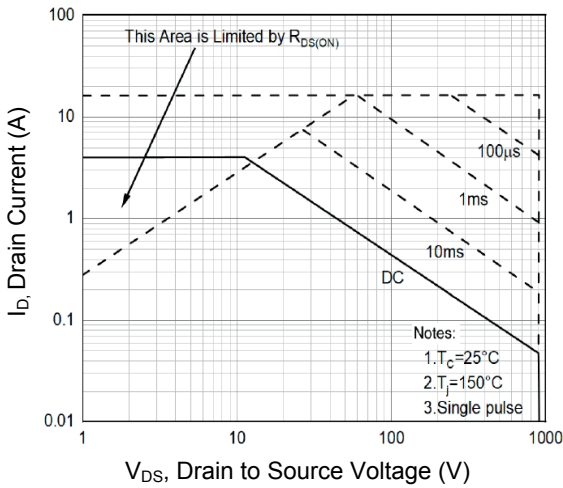

Figure 9. Safe Operation Area

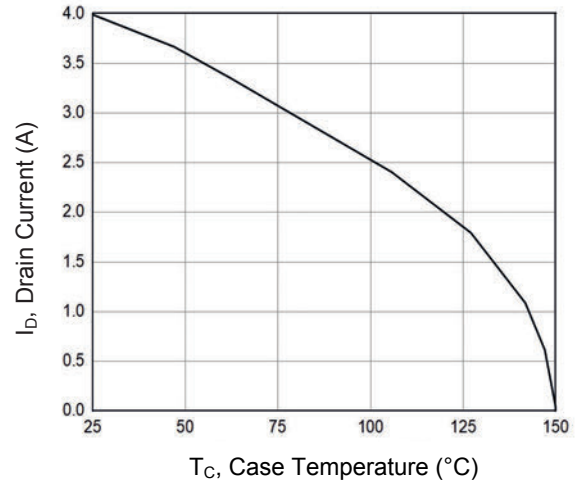
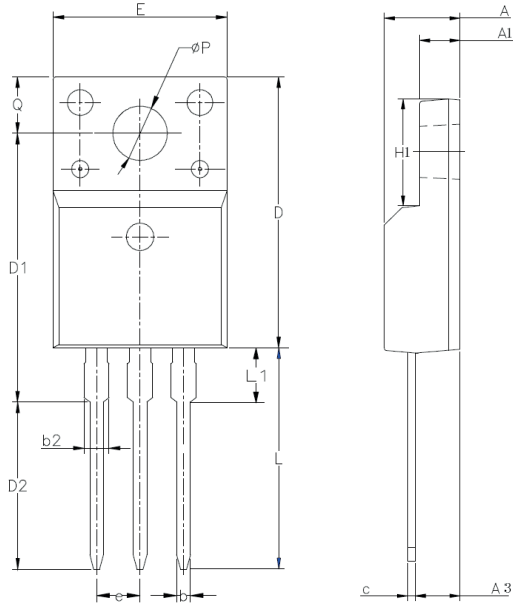

Figure 10. Drain Current vs. T_C

Package Outline Dimensions (TO-220F)



Symbol	Dimensions In Millimeters		Dimensions In Inches	
	Min.	Max.	Min.	Max.
A	4.42	5.02	0.174	0.198
A1	2.30	2.80	0.091	0.110
A3	2.50	3.10	0.098	0.122
b	0.55	0.85	0.022	0.033
b2	-	1.29	-	0.051
c	0.35	0.65	0.014	0.026
D	15.25	16.25	0.600	0.640
D1	13.97	14.97	0.550	0.589
D2	10.58	11.58	0.417	0.456
E	9.73	10.36	0.383	0.408
e	2.54 BCS		0.10 BCS	
H1	6.40	7.00	0.252	0.276
L	12.48	13.48	0.491	0.531
L1	-	2.00	-	0.079
ΦP	3.00	3.40	0.118	0.134
Q	3.05	3.55	0.120	0.140

Ordering Information

Device	Package	Marking	Quantity	HSF Status
GSJU4N90	TO-220F	U4N90	50pcs / Tube	RoHS Compliant