

Main Product Characteristics

BV_{DSS}	-30V
$R_{DS(ON)}$	19m Ω (max.)
I_D	-10A

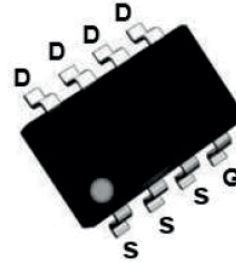

SOP-8

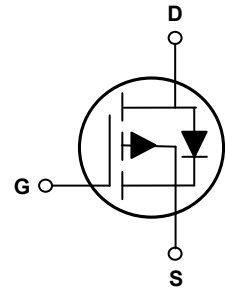

Schematic Diagram

Features and Benefits

- Advanced MOSFET process technology
- Ideal for high efficiency switched mode power supplies
- Low on-resistance with low gate charge
- Fast switching and reverse body recovery



Description

The GSFQ3019 utilizes the latest techniques to achieve high cell density and low on-resistance. These features make this device extremely efficient and reliable for use in high efficiency switch mode power supplies and a wide variety of other applications.

Absolute Maximum Ratings ($T_A=25^\circ\text{C}$ unless otherwise specified)

Parameter	Symbol	Max.	Unit
Drain-Source Voltage	V_{DS}	-30	V
Gate-Source Voltage	V_{GS}	± 25	V
Drain Current-Continuous ($T_C=25^\circ\text{C}$)	I_D	-10	A
Drain Current-Continuous ($T_C=100^\circ\text{C}$)		-8	
Drain Current-Pulsed ¹	I_{DM}	-40	A
Single Pulse Avalanche Energy ²	E_{AS}	54	mJ
Single Pulse Avalanche Current ²	I_{AS}	-33	A
Power Dissipation ($T_C=25^\circ\text{C}$)	P_D	2.7	W
Power Dissipation-Derate above 25 $^\circ\text{C}$		0.022	
Thermal Resistance, Junction-to-Ambient	$R_{\theta JA}$	62	$^\circ\text{C}/\text{W}$
Thermal Resistance, Junction-to-Case	$R_{\theta JC}$	46.2	$^\circ\text{C}/\text{W}$
Operating Junction and Storage Temperature Range	T_J/T_{STG}	-55 to +150	$^\circ\text{C}$

Electrical Characteristics ($T_J=25^\circ\text{C}$ unless otherwise specified)

Parameter	Symbol	Conditions	Min.	Typ.	Max.	Unit
On / Off Characteristics						
Drain-Source Breakdown Voltage	BV_{DSS}	$V_{GS}=0V, I_D=-250\mu A$	-30	-	-	V
BV_{DSS} Temperature Coefficient	$\Delta BV_{DSS}/\Delta T_J$	Reference to 25°C , $I_D=-1\text{mA}$	-	-0.03	-	$V/^\circ\text{C}$
Drain-Source Leakage Current	I_{DSS}	$V_{DS}=-27V, V_{GS}=0V, T_J=25^\circ\text{C}$	-	-	-1	μA
		$V_{DS}=-24V, V_{GS}=0V, T_J=125^\circ\text{C}$	-	-	-10	μA
Gate-Source Leakage Current	I_{GSS}	$V_{GS}=\pm 20V, V_{DS}=0V$	-	-	± 100	nA
Static Drain-Source On-Resistance	$R_{DS(ON)}$	$V_{GS}=-10V, I_D=-8A$	-	16	19	m Ω
		$V_{GS}=-4.5V, I_D=-6A$	-	25	30	
Gate Threshold Voltage	$V_{GS(th)}$	$V_{GS}=V_{DS}, I_D=-250\mu A$	-1.1	-1.6	-2.9	V
$V_{GS(th)}$ Temperature Coefficient	$\Delta V_{GS(th)}$		-	4	-	$\text{mV}/^\circ\text{C}$
Forward Transconductance	gfs	$V_{DS}=-10V, I_D=-8A$	-	6.8	-	S
Dynamic and Switching Characteristics						
Total Gate Charge ^{2,3}	Q_g	$V_{DS}=-15V, I_D=-5A, V_{GS}=-4.5V$	-	11	17	nC
Gate-Source Charge ^{2,3}	Q_{gs}		-	3.4	6	
Gate-Drain Charge ^{2,3}	Q_{gd}		-	4.2	8	
Turn-On Delay Time ^{2,3}	$t_{d(on)}$	$V_{DD}=-15V, R_G=6\Omega, V_{GS}=-10V, I_D=-1A$	-	5.8	11	nS
Rise Time ^{2,3}	t_r		-	18.8	36	
Turn-Off Delay Time ^{2,3}	$t_{d(off)}$		-	46.9	90	
Fall Time ^{2,3}	t_f		-	12.3	23	
Input Capacitance	C_{iss}	$V_{DS}=-15V, V_{GS}=0V, F=1\text{MHz}$	-	1250	2500	pF
Output Capacitance	C_{oss}		-	160	320	
Reverse Transfer Capacitance	C_{rss}		-	90	180	
Source-Drain Ratings and Characteristics						
Continuous Source Current	I_S	$V_G=V_D=0V, \text{Force Current}$	-	-	-10	A
Pulsed Source Current	I_{SM}		-	-	-40	A
Diode Forward Voltage	V_{SD}	$V_{GS}=0V, I_S=-1A, T_J=25^\circ\text{C}$	-	-	-1	V

Notes

1. Repetitive rating: Pulsed width limited by maximum junction temperature.
2. $V_{DD}=-25V, V_{GS}=-10V, L=0.1\text{mH}, I_{AS}=-33A$, starting $T_J=25^\circ\text{C}$.
3. Pulse test: pulse width $\leq 300\mu\text{s}$, duty cycle $\leq 2\%$.
4. Essentially independent of operating temperature.

Typical Electrical and Thermal Characteristic Curves

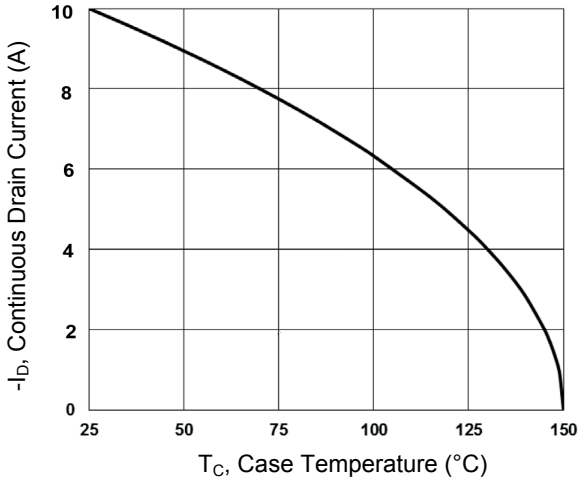

Figure 1. Continuous Drain Current vs. T_C

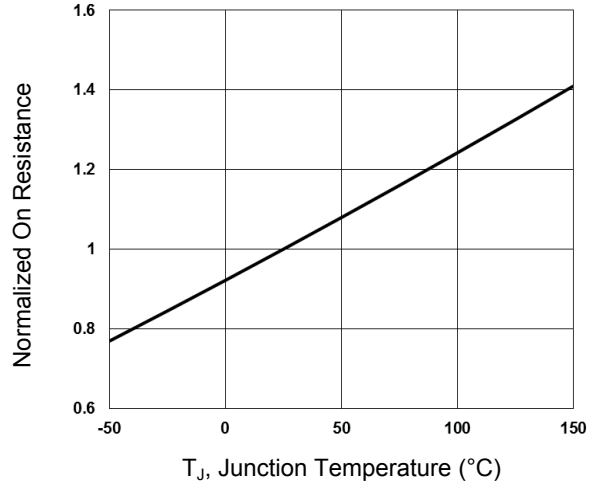

Figure 2. Normalized $R_{DS(ON)}$ vs. T_J

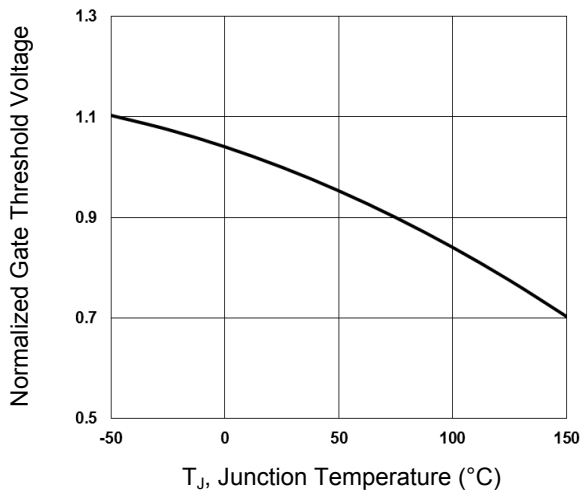

Figure 3. Normalized V_{th} vs. T_J

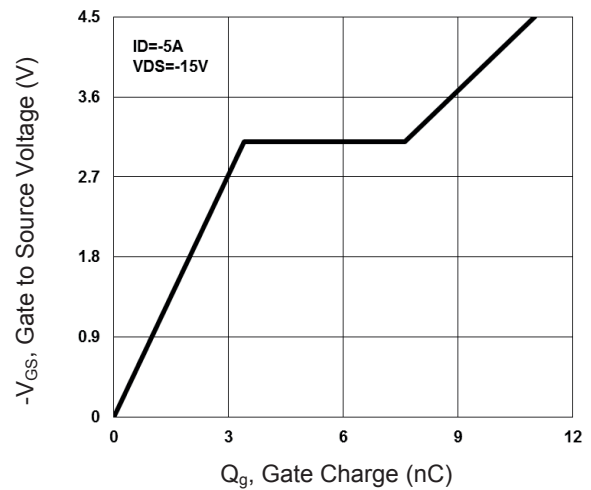

Figure 4. Gate Charge Waveform

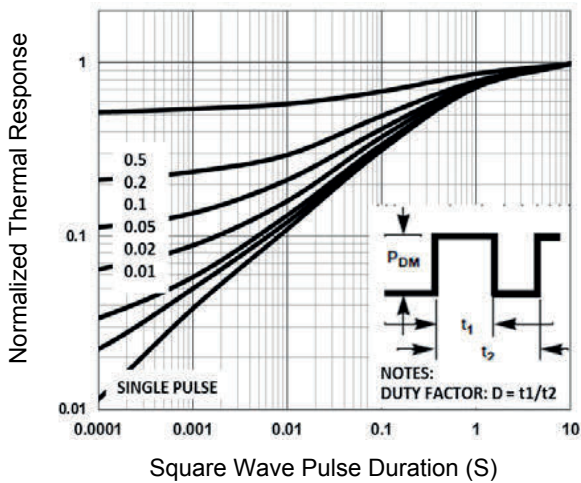

Figure 5. Normalized Transient Impedance

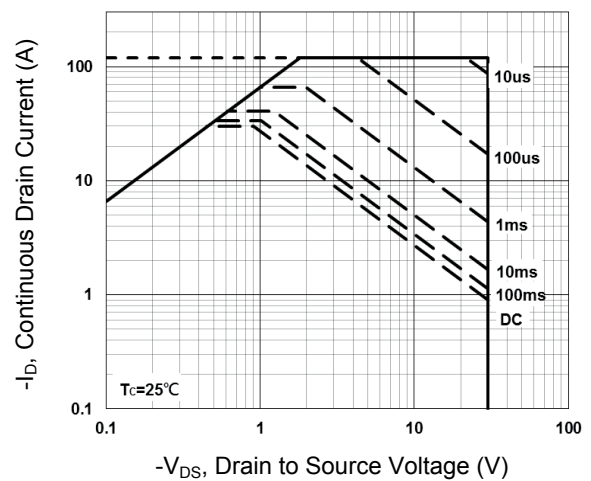
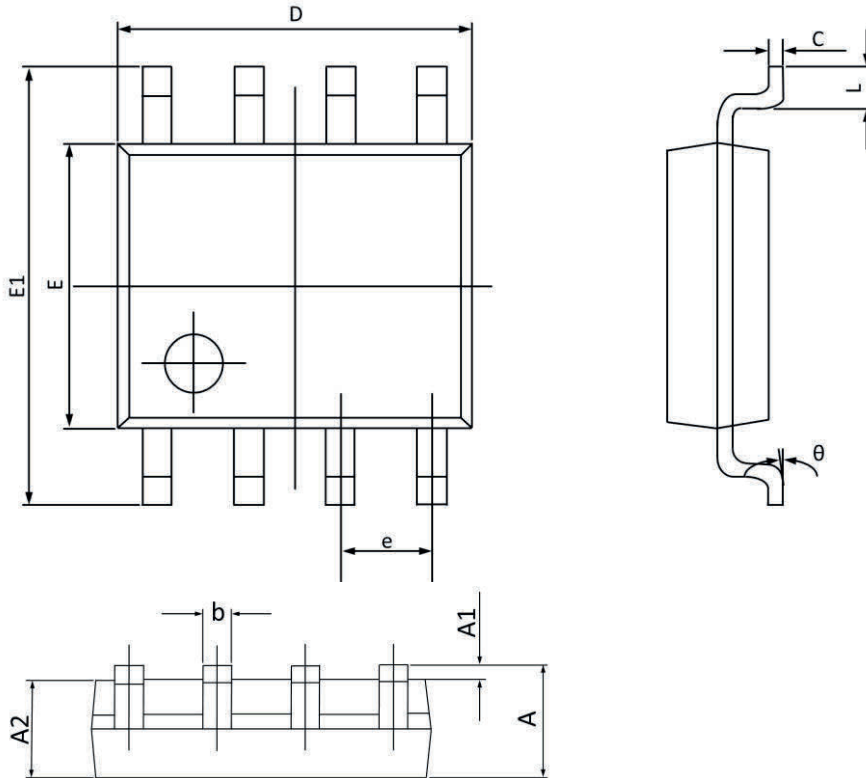

Figure 6. Maximum Safe Operation Area

Package Outline Dimensions (SOP-8)



Symbol	Dimensions In Millimeters		Dimensions In Inches	
	Min	Max	Min	Max
A	1.350	1.750	0.053	0.069
A1	0.100	0.250	0.004	0.010
A2	1.300	1.500	0.051	0.059
b	0.350	0.490	0.014	0.019
C	0.190	0.260	0.007	0.010
D	4.700	5.100	0.185	0.201
E	3.700	4.100	0.146	0.161
E1	5.800	6.200	0.228	0.244
e	1.27 BSC		0.05 BSC	
L	0.400	0.900	0.016	0.035
theta	0°	8°	0°	8°

Order Information

Device	Package	Marking	Carrier	Quantity
GSFQ3019	SOP-8	Q3019	Tape & Reel	3,000 Pcs / Reel